





## APR DISPLAY SYSTEMS

**APR DISPLAY SYSTEMS** has been established in 2010 as a World Class Display Boards & Writing Boards, Accessories and all Products company in Mumbai. Our business model is based on the accomplishment of Display Boards markets in Mumbai. Based on the decision of the company to diversify our Products, We have now established this corporation in India. The Experience of our company is more than 15 Years in the Industry.

**APR DISPLAY SYSTEMS** are the top most manufacturers in supplying of Writing Boards, Display Systems & all Accessories with further commitments and support in the services. There is a great satisfied Clientele in India for fulfilling there all requirements relating to this industry.  
Company Strategy

**Purpose** : To be a leader in the real estate industry by providing enhanced services, relationship and profitability.

**Vision** : To provide quality services that exceeds the expectations of our esteemed customers.  
Core values : We believe in treating our customers with respect and faith, We grow through creativity, invention and innovation. We integrate honesty, integrity and business ethics into all aspects of our business functioning.

**Goals** : Regional expansion in the field of product management and develop a strong base of key customers. Increase the

Reliability and Transparency of the company to support the development of services. To build good reputation in the field of real estate and property management and become a key player in the industry.

For this the organization shall establish and appraise Quality Objectives to focus on.

Building Expertise Competence

Quality Perfection

Consumer Education

Human Resource Development

Customer Support

# INDEX

PAGE NO.

➤ CERAMIC WHITE BOARD (ASTEL SERIES).....	1
➤ CERAMIC GREEN BOARD (ASTEL SERIES).....	2
➤ MAGNETIC WHITE BOARD (ASTEL SERIES).....	3
➤ MAGNETIC GREEN BOARD (ASTEL SERIES).....	4
➤ NON-MAGNETIC WHITE BOARD (ASTEL SERIES).....	5
➤ NON-MAGNETIC GREEN BOARD (ASTEL SERIES).....	6
➤ CERAMIC, MAGNETIC, NON-MAGNETIC WHITE BOARD (ASTEL ECO SERIES).....	7
➤ CERAMIC, MAGNETIC, NON-MAGNETIC GREEN BOARD (ASTEL ECO SERIES).....	8
➤ MAGNETIC GRAPH BOARD (ASTEL SERIES).....	9
➤ NON-MAGNETIC GRAPH BOARD (ASTEL SERIES).....	10
➤ CERAMIC, MAGNETIC & NON-MAGNETIC BOARD (HANGING SERIES).....	11
➤ CERAMIC, MAGNETIC & NON-MAGNETIC WHITE BOARD (HANGING ECO SERIES).....	12
➤ CERAMIC, MAGNETIC & NON-MAGNETIC GREEN BOARD (HANGING ECO SERIES).....	13
➤ CERAMIC, MAGNETIC & NON-MAGNETIC WHITE BOARD (UMEX-CR SERIES).....	14
➤ CERAMIC, MAGNETIC & NON-MAGNETIC GREEN BOARD (UMEX-CR SERIES).....	15
➤ CERAMIC, MAGNETIC & NON-MAGNETIC WHITE BOARD (UMEX-FT SERIES).....	16
➤ CERAMIC, MAGNETIC & NON-MAGNETIC GREEN BOARD (UMEX-FT SERIES).....	17
➤ NON-MAGNETIC GLASS BOARD.....	18
➤ MAGNETIC GLASS BOARD.....	19
➤ FELT PIN UP NOTICE BOARD (ASTEL SERIES).....	20
➤ FABRIC PIN UP NOTICE BOARD (ASTEL SERIES).....	21
➤ CORK PIN UP NOTICE BOARD (ASTEL SERIES).....	22
➤ FELT/FABRIC/CORK PIN UP NOTICE BOARD (ECO ASTEL SERIES).....	23
➤ FELT/FABRIC PIN UP NOTICE BOARD (HANGING SERIES).....	24
➤ FELT/FABRIC/CORK PIN UP NOTICE BOARD (ECO HANGING SERIES).....	25
➤ FELT/FABRIC/CORK PIN UP NOTICE BOARD (UMEX-CR SERIES).....	26
➤ FELT/FABRIC/CORK PIN UP NOTICE BOARD (UMEX-FT SERIES).....	27
➤ COMBINATION BOARD.....	28
➤ DOUBLE SIDED BOARD (ASTEL SERIES).....	29
➤ DOUBLE SIDED BOARD (HANGING SERIES).....	30
➤ GROOVE BOARD (ASTEL SERIES).....	31
➤ PERFORATED DISPLAY BOARD (ASTEL SERIES).....	32
➤ PERFORATED DISPLAY BOARD WITH LETTERS & FIGURES.....	33
➤ DOOR COVERED NOTICE BOARD.....	34
➤ SLIDING GLASS DOOR COVER BOARD.....	35
➤ KEY BOARD.....	36
➤ DOOR COVERED BOARD WITH LED LIGHTING SYSTEM.....	37
➤ KIDZ BOARD, STUDY TABLE, LOBBY INFORMATION BOARD.....	38
➤ EXHIBITION DISPLAY BOARD.....	39
➤ DIM KIT & PLANNER BOARD.....	40
➤ BOARD STANDS.....	41
➤ BOARD STANDS.....	42
➤ FIXED TYPE MOVABLE STAND.....	43
➤ BOARD STAND.....	44
➤ BOARD ACCESSORIES.....	45
➤ BOARD ACCESSORIES.....	46
➤ ACRYLIC PRODUCTS.....	47
➤ ACRYLIC PRODUCTS.....	48
➤ SLIDING GLASS BOARD ASSEMBLY PROCEDURE.....	49
➤ LINE DIAGRAM FOR MOUNTING OF THE BOARD ON THE WALL.....	50
➤ LINE DIAGRAM FOR FITTING OF PLASTIC PEN TRAY ON THE ASTEL FRAME BOARD.....	51
➤ GUIDE FOR CARE & MAINTENANCE OF WHITE MARKER / CHALK BOARD.....	52



## CERTIFICATE

*This is to Certify that the  
Quality Management System  
of*

### APR DISPLAY SYSTEMS

OFFICE ADDRESS - ROOM NO. 29, 1 ST FLOOR, SURESH BHAVAN,  
CHINCHOLI BUNDER ROAD, MALAD (WEST), MUMBAI - 400 064,  
MAHARASHTRA, INDIA.

FACTORY ADDRESS - GALA NO. 5, KRUSINGAL INDUSTRIAL ESTATE, WALIV PHATA,  
TAL. - VASAI, DIST. PALGHAR - 401208, MAHARASHTRA, INDIA.

Has been independently assessed and is compliant  
with the requirements of

**ISO 9001:2015**

This certificate is applicable to the following product or service ranges:

MANUFACTURER OF WRITING & DISPLAY BOARDS.

## ASSESSMENTS

:: Certificate No :: IN113358A

### QUALITY MANAGEMENT SYSTEM

Date of initial registration	25 July 2018
Date of this certificate	25 July 2018
Surveillance audit on or before	24 July 2019
Recertification Due / Certificate expiry	24 July 2021

This Certificate is property of LMS Certifications and remains valid  
subject to satisfactory surveillance audits.



Director



LMS Certifications Private Limited  
1-Ananddham, Opp. Kukrail Picnic Spot Gate,  
Farid Nagar, Lucknow - 226015, UP, (INDIA).  
e-mail > info@lmsassessments.com,  
Visit > www.lmsassessments.com.



## CERAMIC WHITE BOARD

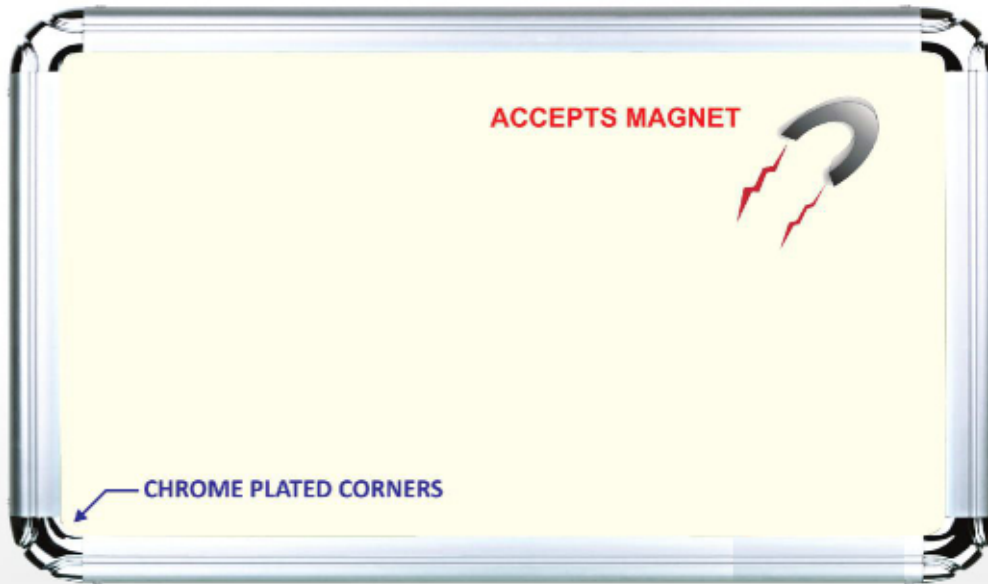

- With its smart, premium enamel coated surface, the Vitreous Enamel Green Chalk Board is the super tough & Superior Quality Writing Board.
- Popularly know as Vitreous Enamel Writing surface gives stylish & Smooth experience and evolves less dust while writing.
- Thickness of the Surface is 0.56 mm is Durable for hard-wearing & is totally scratch proof and chip-resistant, making the board more ideal for Intensive use. With an outstanding 25 years surface warranty (subject to normal use), this enamel board is built to last for a longer time. You can purchase this board With total confidence.
- Attracts Magnets so one can use magnetic Buttons or Magnetic Push Pins to attach printed sheets on the surface of the board while illustrating.
- Durable with its tough, anodized finish, the aluminum frame can withstand everyday wear and tear and stay looking good forever.
- Day-to-day cleaning with a Standard Magnetic Duster/ Erasers whilst a good clean Surface, Proper maintaince of the Board will ensure surfaces remain in Tip-top condition with no ghost images and you can be sure of communicating a clear messages time after time.
- Following The instructions provided, any persons can manage this task easily and safely install the board on the wall using spares supplied inside each Board.
- Pen tray can be purchased separately, so you can keep a selection of all coloured Chalks close to hand.

SIZE (MM) APPROX.	SIZE (MM) APPROX.	SIZE (MM) APPROX.
300X450	600X1500	1200X3000
300X600	600X1800	1200X3600
450X600	900X1200	—
450X900	1200X1200	—
600X600	1200X1500	—
600X900	1200X1800	—
600X1200	1200X2400	—

**MAGNETIC WHITE BOARD**



- With its premium, Triple Acrylic Resin Coated steel surface, Astel Magnetic Steel Drywipe Board is both stylish and durable.
- This dual-purpose drywipe writing board and magnetic notice board is perfect for personal workstations, Offices, Cabins, Institutions or break-out areas in busy, professional environments. Attracts Magnets so one can use magnetic Buttons or Magnetic Push Pins to attach printed sheets on the surface of the board while illustrating.
- Thickness of the magnetic steel surface being 0.40 mm is chip resistant, making the Board ideal for frequent use.
- The clean smooth, contemporary Surface gives advantages for excellent quality writing & will speak volumes about the image of your company.
- Day-to-day cleaning with a Standard Magnetic Duster/ Erasers whilst a good clean Surface, Good Quality marker pens & proper maintenance of the Board will ensure surfaces remain in tip-top condition with no grease or ghost images left behind.
- Durable with its tough, anodized finish, the aluminum frame can withstand everyday wear and tear and stay looking good forever.
- Following the instructions provided, any persons can manage this task easily and safely install the board on the wall using spares supplied inside each board.
- Pen tray can be purchased separately, so you can keep a selection of all coloured Makers close to hand.

SIZE (MM) APPROX.	SIZE (MM) APPROX.	SIZE (MM) APPROX.
300X300	600X1500	1200X1200
300X450	600X1800	1200X1500
300X600	900X900	1200X1800
450X600	900X1200	1200X2400
450X900	900X1500	1200X3000
600X600	900X1800	1200X3600
600X900	900X2400	----
600X1200	900X3000	----

## MAGNETIC GREEN BOARD



- With its premium, Triple Acrylic Resin Coated steel surface, Astel Magnetic Green Chalk writing Steel Board is both stylish and durable.
- This dual-purpose writing board and magnetic notice board is perfect for Schools, Institutions, Private Tuitions in busy, professional environments. Attracts Magnets so one can use magnetic Buttons or Magnetic Push Pins to attach printed sheets on the surface of the board while illustrating.
- Thickness of the magnetic steel surface being 0.40 mm is chip resistant, making the Board ideal for frequent use.
- The clean smooth, contemporary Surface gives advantages for excellent quality writing & and evolves less dust while writing with Chalks..
- Day-to-day cleaning with a Standard Chalk Board Duster whilst a good clean Surface, Good Quality Dustless Chalks & Proper maintenance of the Board will ensure surfaces remain in tip-top condition with no ghost images left behind.
- Durable with its tough, anodized finish, the aluminum frame can withstand everyday wear and tear and stay looking good forever.
- Following the instructions provided, any persons can manage this task easily and safely install the board on the wall using spares supplied inside each board.
- Pen tray can be purchased separately, so you can keep a selection of all coloured Chalks close to hand.

SIZE (MM) APPROX.	SIZE (MM) APPROX.	SIZE (MM) APPROX.
300X300	600X1500	1200X1200
300X450	600X1800	1200X1500
300X600	900X900	1200X1800
450X600	900X1200	1200X2400
450X900	900X1500	1200X3000
600X600	900X1800	1200X3600
600X900	900X2400	----
600X1200	900X3000	----

**NON-MAGNETIC WHITE BOARD**



- With its modern, aluminium frame & Chrome Plated Corners, the tough surface, of the new Astel Extra Melamine Drywipe Board is both smart and economical.
- This drywipe board is the practical choice for individual workstations or at home where wall space is limited. Leave messages, write notes or list priority tasks and get yourself organized for the day ahead.
- The durable, melamine surface is chip-resistant. & is Ideal for general use & does not attract Magnets.
- Day-to-Day cleaning with a standard Non-Magnetic Duster/Erasers or with wet cloth whilst a good clean surface. Good Quality Marker Pens & proper maintenance of the board will ensure surfaces remain in tip-top condition with no grease or ghost images left behind.
- Durable with its tough, anodized finish, the aluminum frame can withstand everyday wear and tear and stay looking good forever.
- Following the instructions provided, any person can manage this task easily and safely install the board on the wall using spares supplied inside each board.
- Pen tray can be purchased separately, so you can keep a selection of drywipe markers close to hand.

SIZE (MM) APPROX.	SIZE (MM) APPROX.	SIZE (MM) APPROX.
300X300	600X1500	1200X1500
300X450	600X1800	1200X1800
300X600	900X900	1200X2400
450X600	900X1200	1200X3000
450X900	900X1500	1200X3600
600X600	900X1800	----
600X900	900X2400	----
600X1200	1200x1200	----



## NON-MAGNETIC GREEN BOARD



- With its modern, aluminium frame & Chrome Plated Corners, the tough non magnetic surface of the new Astel Melamine Chalk Board is both smart and economical.
- This Green chalk board is the practical choice for individuals at home, at Schools, Institutions Etc....
- The durable, melamine surface is totally Scratch proof and Chip-resistant and evolves less dust while writing with Chalks.
- Surface is Ideal for general use & does not attract Magnets.
- Day-to-day writing can be easily erased with a Standard Non-Magnetic Duster or with a wet cloth for a good clean Surface, Good Quality Dustless Chalks & proper maintenance of the Board will ensure surfaces remain in tip-top condition with no ghost images left behind.
- Durable with its tough, anodized finish, the aluminum frame can withstand everyday wear and tear and stay looking good forever.
- Following the instructions provided, any persons can manage this task easily and safely install the board on the wall using spares supplied inside each board.
- Pen tray can be purchased separately, so you can keep a selection of all coloured Chalks close to hand.

SIZE (MM) APPROX.	SIZE (MM) APPROX.	SIZE (MM) APPROX.
300X300	600X1500	1200X1500
300X450	600X1800	1200X1800
300X600	900X900	1200X2400
450X600	900X1200	1200X3000
450X900	900X1500	1200X3600
600X600	900X1800	----
600X900	900X2400	----
600X1200	1200x1200	----

## CERAMIC, MAGNETIC, NON-MAGNETIC WHITE BOARD

### CERAMIC WHITE BOARD



### MAGNETIC WHITE BOARD



### NON-MAGNETIC WHITE BOARD



#### CERAMIC WHITE BOARD

- Premium Enamel coated Surface. Thickness of the Surface is 0.56mm.
- Ceramic White Board can be used for writing cum OHP Projection Screen, also attracts magnets, Magnetic Display Folders etc.
- Can be utilized as Smart Board with attachment of Smart Board Kit.
- 25 Years Surface Warranty. Scratch & Stain Resistant.

#### NON-MAGNETIC WHITE BOARD

- Non-Magnetic Board offers a smooth writing platform & is very reliable.
- The basic raw material is paper based laminate coated with melamine therefore ink absorption of the marker ink is very less.
- We have developed such sheet from our past experience which gives better writing & erasing.

#### MAGNETIC WHITE BOARD

- Triple Acrylic Resin Coated Steel Surface. Thickness of the Surface is 0.40mm.
- High quality, durable marker board. Also attracts magnets, Magnetic Display Folders etc.
- Smooth surface and glossy with proper hardness.
- Can be used to display notices with the help of Magnetic Buttons/ Magnetic Push Pins.

Following the instructions provided, any persons can manage this task easily and safely install the board on the wall using spares supplied inside each board.

CERAMIC SIZES (MM) APPROX.		MAGNETIC SIZES (MM) APPROX.			NON MAGNETIC SIZES (MM) APPROX.		
300X450	900X1200	300X300	600X1800	1200X1800	300X300	600X1800	1200X2400
300X600	1200X1200	300X450	900X900	1200X2400	300X450	900X900	1200X3000
450X600	1200X1500	300X600	900X1200	1200X3000	300X600	900X1200	1200X3600
450X900	1200X1800	450X600	900X1500	1200X3600	450X600	900X1500	----
600X600	1200X2400	450X900	900X1800	----	450X900	900X1800	----
600X900	1200X3000	600X600	900X2400	----	600X600	900X2400	----
600X1200	1200X3600	600X900	900X3000	----	600X900	1200X1200	----
600X1500	----	600X1200	1200X1200	----	600X1200	1200X1500	----
600X1800	----	600X1500	1200X1500	----	600X1500	1200X1800	----

## CERAMIC, MAGNETIC, NON-MAGNETIC WHITE BOARD

### CERAMIC GREEN BOARD



### MAGNETIC GREEN BOARD



### NON-MAGNETIC GREEN BOARD



#### CERAMIC GREEN BOARD

- Maximum refraction makes board viewable easily from all corners of the classroom. Deep green colour makes fantastic contrast, make board visible easily even from last row of the classroom.
- Creates negligible chalk dust providing clean classroom.
- 25 Years Surface Warranty.

#### NON-MAGNETIC GREEN BOARD

- The basic raw material is paper based laminate coated with melamine.
- The Scratch Proof surface works same as glass board but at economy.
- We have developed such sheet from our past experience which gives better writing & erasing.
- In addition to this if you purchase from standard company, which can offer after sales service.

#### MAGNETIC GREEN BOARD

- Triple Resin Coated Steel Surface. Thickness of the Surface is 0.40mm.
- High quality, durable marker board. Also attracts magnets, Magnetic Display Folders etc.
- Smooth surface and proper hardness evokes less dust while writing.
- Can be used to display notices with the help of Magnetic Buttons/ Magnetic Push Pins.

Following the instructions provided, any persons can manage this task easily and safely install the board on the wall using spares supplied inside each board.

CERAMIC SIZES (MM) APPROX.		MAGNETIC SIZES (MM) APPROX.			NON MAGNETIC SIZES (MM) APPROX.		
300X450	900X1200	300X300	600X1800	1200X1800	300X300	600X1800	1200X2400
300X600	1200X1200	300X450	900X900	1200X2400	300X450	900X900	1200X3000
450X600	1200X1500	300X600	900X1200	1200X3000	300X600	900X1200	1200X3600
450X900	1200X1800	450X600	900X1500	1200X3600	450X600	900X1500	----
600X600	1200X2400	450X900	900X1800	----	450X900	900X1800	----
600X900	1200X3000	600X600	900X2400	----	600X600	900X2400	----
600X1200	1200X3600	600X900	900X3000	----	600X900	1200X1200	----
600X1500	----	600X1200	1200X1200	----	600X1200	1200X1500	----
600X1800	----	600X1500	1200X1500	----	600X1500	1200X1800	----

**MAGNETIC GRAPH BOARD**

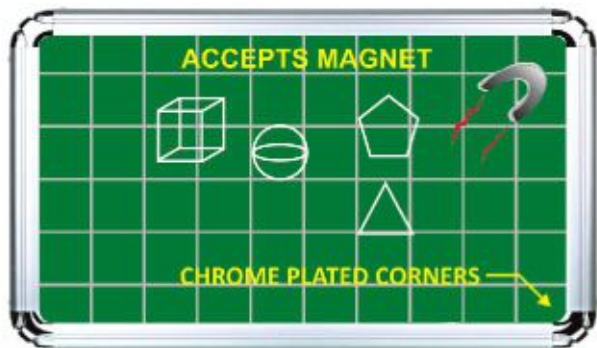

**UMEX-CR SERIES**

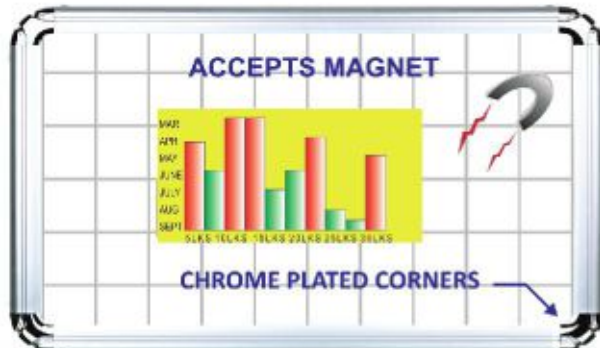

**UMEX-FT SERIES**



- With its premium, Triple Acrylic Resin Coated steel surfaces, Magnetic Writing Boards are both stylish and durable.
- This dual-purpose writing board and magnetic notice board is perfect for Schools, Institutions, Private Tuitions in busy, professional environments. Attracts Magnets so one can use magnetic Buttons or Magnetic Push Pins to attach printed sheets on the surface of the board while illustrating.
- Thickness of the magnetic steel surface being 0.40 mm is chip resistant, making the Board ideal for frequent use.
- The clean smooth, contemporary Surface gives advantages for excellent quality writing.
- 5 cms X 5cms graph available for writing and drawing on both the surfaces.
- Day-to-day cleaning with a Standard Chalk Board Duster for green chalk surface &, Standard Magnetic Duster/ Erasers used for a white marker surface, whilst a good clean Surface. Usage of Good Quality Chalks / marker pens & Proper maintenance of the Board will ensure surfaces remain in tip-top condition with no ghost images left behind.
- Durable with its tough, anodized finish, the aluminum frame can withstand everyday wear and tear and stay looking good forever.
- Following the instructions provided, any persons can manage this task easily and safely install the board on the wall using spares supplied inside each board.
- Pen tray can be purchased separately, so you can keep a selection of all coloured Chalks close to hand.

SIZE (MM) APPROX.	SIZE (MM) APPROX.	SIZE (MM) APPROX.
300X300	600X1500	1200X1200
300X450	600X1800	1200X1500
300X600	900X900	1200X1800
450X600	900X1200	1200X2400
450X900	900X1500	1200X3000
600X600	900X1800	1200X3600
600X900	900X2400	----
600X1200	900X3000	----

**NON-MAGNETIC GRAPH BOARD**

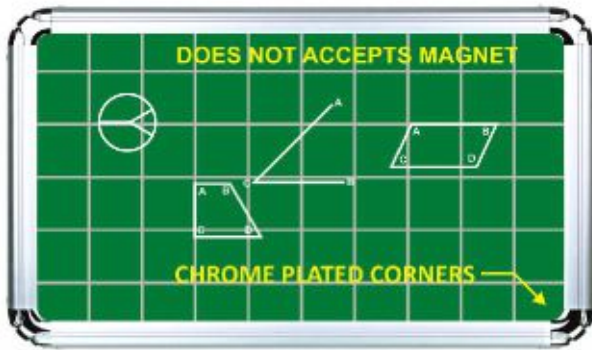

**UMEX-CR SERIES**

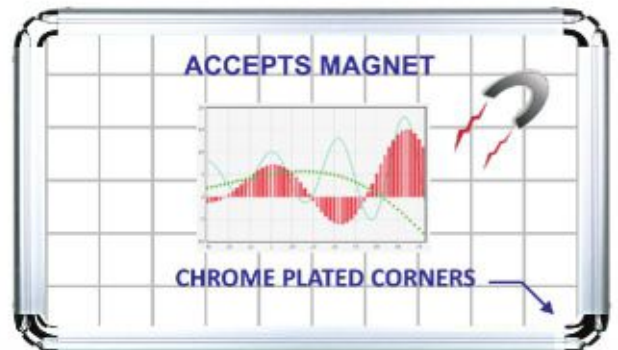

**UMEX-FT SERIES**



- With its modern, aluminium frame & Chrome Plated Corners, the tough surface, of the new ASTEL Extra Melamine Chalk & Dry wipe Board is both smart and economical.
- This Green Chalk Board & drywipe board is the practical choice for individual workstations or at home where wall space is limited. Leave messages, write notes or list priority tasks and get yourself organized for the day ahead.
- The durable, melamine surface is chip-resistant. & is ideal for general use & does not attract Magnets.
- 5cms X 5cms graph available for writing and drawing on both the surfaces.
- Day-to-day cleaning with a Standard Chalk Board Duster for green chalk surface & Standard Non-Magnetic Duster/ Erasers used for a white marker surface, whilst a good clean surface. Usage of Good Quality Chalks / marker pens & Proper maintenance of the Board will ensure surfaces remain in tip-top condition with no ghost images left behind.
- Durable with its tough, anodized finish, the aluminum frame can withstand everyday wear and tear and stay looking good forever.
- Following the instructions provided, any persons can manage this task easily and safely install the board on the wall using spares supplied inside each board.
- Pen tray can be purchased separately, so you can keep a selection of all coloured chalks / drywipe markers close to hand.

SIZE (MM) APPROX.	SIZE (MM) APPROX.	SIZE (MM) APPROX.
300X300	600X1500	1200X1200
300X450	600X1800	1200X1500
300X600	900X900	1200X1800
450X600	900X1200	1200X2400
450X900	900X1500	1200X3000
600X600	900X1800	1200X3600
600X900	900X2400	----
600X1200	900X3000	----

**CERAMIC, MAGNETIC & NON MAGNETIC BOARD**

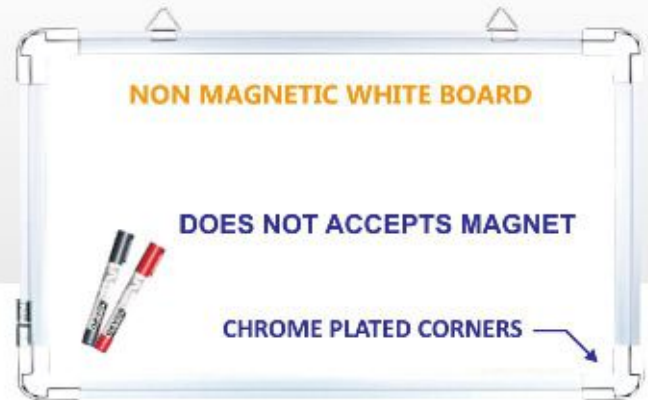
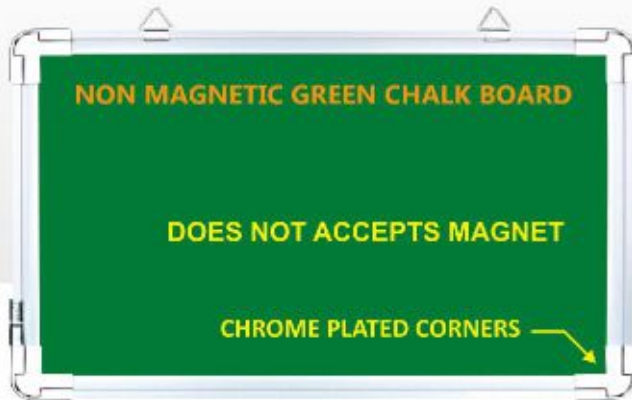
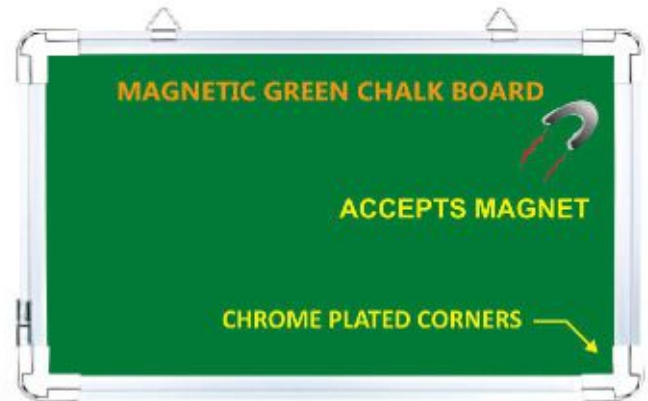
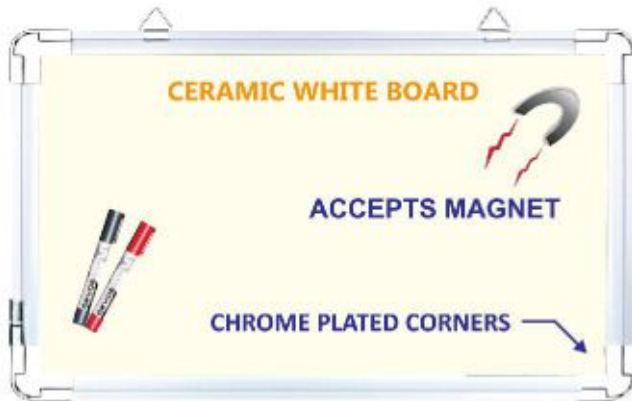

**CERAMIC BOARD**

- Ceramic coated imported steel surface.
- Thickness of the surface being 0.56mm, is totally crack proof/scratch resistance and attracts magnets.
- Available in White colour for writing with markers & Green colour for writing with Chalks.

**MAGNETIC BOARD**

- Triple acrylic resin coated imported steel surface.
- Thickness of the surface being 0.40mm, is totally crack proof and attracts magnets.
- Available in White colour for writing with markers & Green colour for writing with Chalks.

**NON MAGNETIC BOARD**

- Have smooth economical non magnetic extra melamine coated writing surface. Does not attracts magnets.
- Images goes on wet, dries instantly and is removed easily with a standard non magnetic duster.
- Available in White colour for writing with markers & Green colour for writing with Chalks.

CERAMIC SIZE (MM)APPROX.	MAGNETIC SIZE (MM)APPROX.			NON MAGNETIC SIZE (MM)APPROX.		
600X900	300X300	600X1200	1200X1500	300X300	600X1200	1200X1500
900X1200	300X450	600X1800	1200X1800	300X450	600X1800	1200X1800
1200X1200	300X600	900X900	1200X2400	300X600	900X900	1200X2400
1200X1500	450X600	900X1200	----	450X600	900X1200	----
1200X1800	450X900	900X1500	----	450X900	900X1500	----
----	600X600	900X1800	----	600X600	900X1800	----
----	600X900	1200X1200	----	600X900	1200X1200	----

## CERAMIC, MAGNETIC, NON-MAGNETIC WHITE BOARD

### CERAMIC WHITE BOARD



### MAGNETIC WHITE BOARD



### NON-MAGNETIC WHITE BOARD

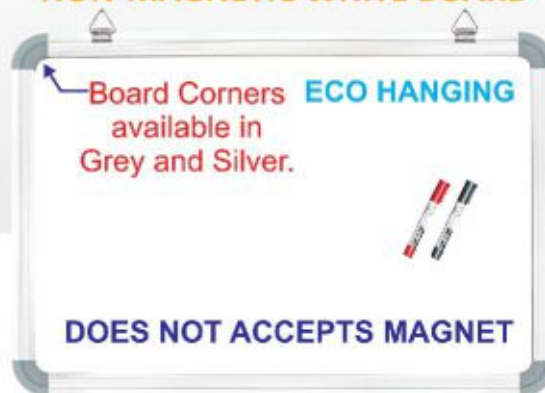

#### CERAMIC WHITE BOARD

- Premium Enamel coated Surface. Thickness of the Surface is 0.56mm.
- Ceramic White Board can be used for writing cum OHP Projection Screen, also attracts magnets, Magnetic Display Folders etc.
- Can be utilized as Smart Board with attachment of Smart Board Kit.
- 25 Years Surface Warranty. Scratch & Stain Resistant.

#### MAGNETIC WHITE BOARD

- Triple Acrylic Resin Coated Steel Surface. Thickness of the Surface is 0.40mm.
- High quality, durable marker board. Also attracts magnets, Magnetic Display Folders etc.
- Smooth surface and glossy with proper hardness.
- Can be used to display notices with the help of Magnetic Buttons/ Magnetic Push Pins.

#### NON-MAGNETIC WHITE BOARD

- Non-Magnetic Board offers a smooth writing platform & is very reliable.
- The basic raw material is paper based laminate coated with melamine therefore ink absorption of the marker ink is very less.
- We have developed such sheet from our past experience which gives better writing & erasing.

Following the instructions provided, any persons can manage this task easily and safely install the board on the wall using spares supplied inside each board.

CERAMIC SIZES (MM) APPROX.		MAGNETIC SIZES (MM) APPROX.			NON MAGNETIC SIZES (MM) APPROX.		
300X450	900X1200	300X300	600X1800	1200X1800	300X300	600X1800	1200X2400
300X600	1200X1200	300X450	900X900	1200X2400	300X450	900X900	----
450X600	1200X1500	300X600	900X1200	1200X3000	300X600	900X1200	----
450X900	1200X1800	450X600	900X1500	1200X3600	450X600	900X1500	----
600X600	1200X2400	450X900	900X1800	----	450X900	900X1800	----
600X900	1200X3000	600X600	900X2400	----	600X600	900X2400	----
600X1200	1200X3600	600X900	900X3000	----	600X900	1200X1200	----
600X1500	----	600X1200	1200X1200	----	600X1200	1200X1500	----
600X1800	----	600X1500	1200X1500	----	600X1500	1200X1800	----

**CERAMIC, MAGNETIC & NON MAGNETIC WHITE BOARD**

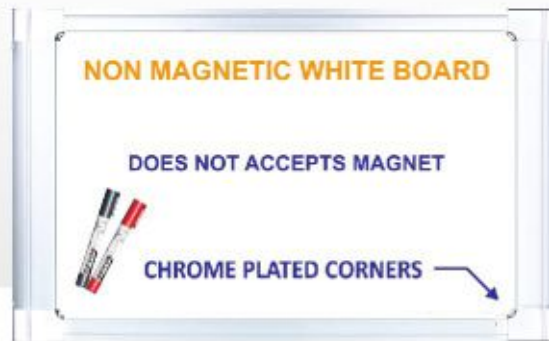
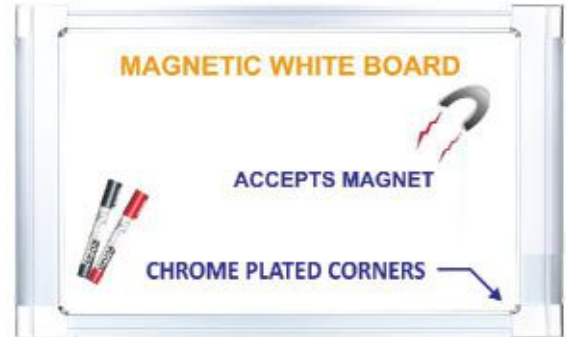
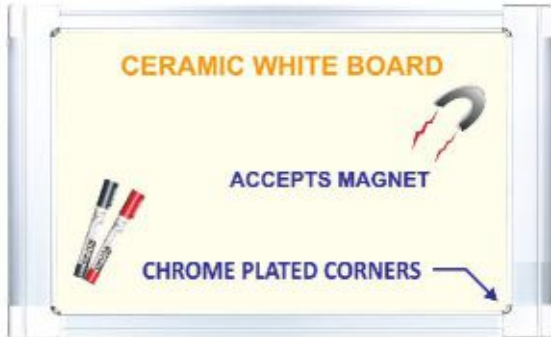

**CERAMIC WHITE BOARD**

- Premium enamel coated surface with thickness of 0.56 mm. Is durable for hard-wearing & is totally scratch proof and chip-resistant making the board more ideal for intensive use. With an outstanding 25years surface warranty (subject to normal use), this enamel board is built to last for a longer time. Semi matte magnetic surface offers dual-purpose projection cum writing.

**MAGNETIC WHITE BOARD**

- Premium triple acrylic resin coated steel surface with thickness of 0.40 mm. Is chip resistant, making the board ideal for frequent use. The clean smooth, contemporary surface gives advantages for excellent quality writing & will speak volumes about the image of your company. Day-to-Day cleaning with a standard magnetic duster/erasers whilst a good clean surface, good quality marker pens & proper maintenance of the board will ensure remain in tip top condition with no grease or ghost images left behind.

**NON-MAGNETIC WHITE BOARD**

- The durable, melamine surface is chip-resistant & is ideal for general use & does not attracts magnets. Durable with its tough, anodized finish the aluminium frame can withstand everyday wear and tear and stay looking good forever.

**CERAMIC BOARD**

SIZE (MM) APPROX.	SIZE (MM) APPROX.
600X900	1200X1800
600X1200	1200X2400
600X1800	1200X3000
900X1200	1200X3200
1200X1500	----

**MAGNETIC / NON MAGNETIC BOARD**

SIZE (MM) APPROX.	SIZE (MM) APPROX.	SIZE (MM) APPROX.
600X900	900X1200	1200X2400
600X1200	900X1500	1200X3000
600X1800	900X1800	1200X3200
900X900	1200X1500	----
900X1200	1200X1800	----



**CERAMIC, MAGNETIC & NON MAGNETIC GREEN BOARD**



**CERAMIC GREEN BOARD**

- Premium enamel coated surface with thickness of 0.56 mm., the UMEX-CR Magnetic Enamel Green Chalk Board Is durable for hard-wearing & is totally scratch proof and chip-resistant making the board more ideal for intensive use. With an outstanding 25years surface warranty (subject to normal use), this enamel board is built to last for a longer time. Semi matte magnetic surface offers dual-purpose projection cum writing.

**MAGNETIC GREEN BOARD**

- Premium triple acrylic resin coated steel surface with thickness of 0.40 mm. Is chip resistant, making the board ideal for frequent use. The clean smooth, contemporary surface gives advantages for excellent quality writing & will speak volumes about the image of your company. Day-to-Day cleaning with a standard magnetic duster/erasers whilst a good clean surface, good quality marker pens & proper maintenance of the board will ensure remain in tip top condition with no grease or ghost images left behind.

**NON-MAGNETIC GREEN BOARD**

- The durable, melamine surface is chip-resistant & is ideal for general use & does not attract magnets. Durable with its tough, anodized finish the aluminium frame can withstand everyday wear and tear and stay looking good forever.

**CERAMIC BOARD**

SIZE (MM) APPROX.	SIZE (MM) APPROX.
600X900	1200X1800
600X1200	1200X2400
600X1800	1200X3000
900X1200	1200X3200
1200X1500	----

**MAGNETIC / NON MAGNETIC BOARD**

SIZE (MM) APPROX.	SIZE (MM) APPROX.	SIZE (MM) APPROX.
600X900	900X1200	1200X2400
600X1200	900X1500	1200X3000
600X1800	900X1800	1200X3200
900X900	1200X1500	----
900X1200	1200X1800	----

**CERAMIC, MAGNETIC & NON MAGNETIC WHITE BOARD**

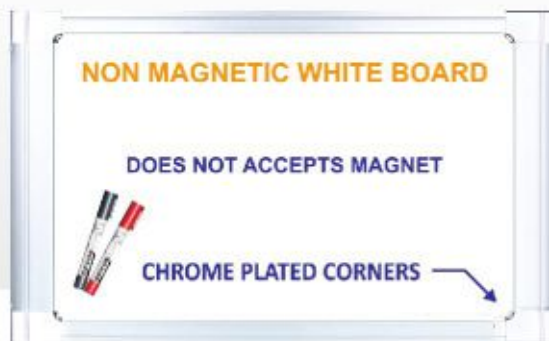
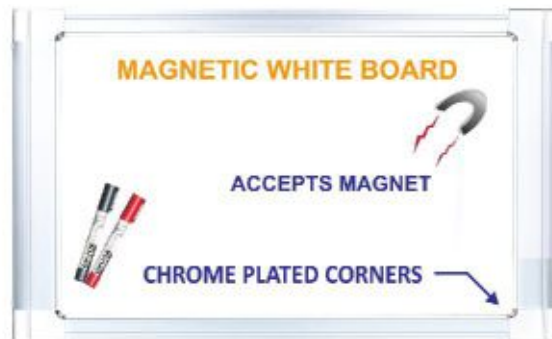
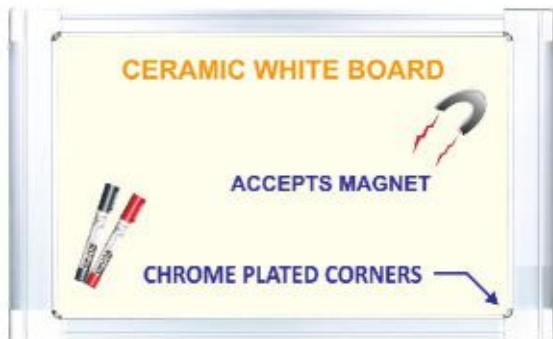

**CERAMIC WHITE BOARD**

- Premium enamel coated surface with thickness of 0.56 mm. Is durable for hard-wearing & is totally scratch proof and chip-resistant making the board more ideal for intensive use. With an outstanding 25years surface warranty (subject to normal use), this enamel board is built to last for a longer time. Semi matte magnetic surface offers dual-purpose projection cum writing.

**MAGNETIC WHITE BOARD**

- Premium triple acrylic resin coated steel surface with thickness of 0.40 mm. Is chip resistant, making the board ideal for frequent use. The clean smooth, contemporary surface gives advantages for excellent quality writing & will speak volumes about the image of your company. Day-to-Day cleaning with a standard magnetic duster/erasers whilst a good clean surface, good quality marker pens & proper maintenance of the board will ensure remain in tip top condition with no grease or ghost images left behind.

**NON-MAGNETIC WHITE BOARD**

- The durable, melamine surface is chip-resistant & is ideal for general use & does not attracts magnets. Durable with its tough, anodized finish the aluminium frame can withstand everyday wear and tear and stay looking good forever.

CERAMIC BOARD		MAGNETIC BOARD			NON-MAGNETIC BOARD		
SIZE (MM) APPROX.	SIZE (MM) APPROX.	SIZE (MM) APPROX.	SIZE (MM) APPROX.	SIZE (MM) APPROX.	SIZE (MM) APPROX.	SIZE (MM) APPROX.	SIZE (MM) APPROX.
300X450	600X1800	300X450	600X1800	1200X1500	300X450	600X1800	1200X1800
300X600	900X1200	300X600	900X900	1200X1800	300X600	900X900	1200X2400
450X600	1200x1200	450X600	900X1200	1200X2400	450X600	900X1200	1200X3000
450X900	1200X1500	450X900	900X1500	1200X3000	450X900	900X1500	1200X3600
600X600	1200X1800	600X600	900X1800	1200X3600	600X600	900X1800	----
600X900	1200X2400	600X900	900X2400	----	600X900	900X2400	----
600X1200	1200X3000	600X1200	900X3000	----	600X1200	1200x1200	----
600X1500	1200X3600	600X1500	1200x1200	----	600X1500	1200X1500	----

**CERAMIC, MAGNETIC & NON MAGNETIC GREEN BOARD**



**CERAMIC GREEN BOARD**

- Premium enamel coated surface with thickness of 0.56 mm., the AllArk UMEX-CR Magnetic Enamel Green Chalk Board Is durable for hard-wearing & is totally scratch proof and chip-resistant making theboard more ideal for intensive use. With an outstanding 25years surface warranty (subject to normal use), this enmel board is built to last for a longer time. Semi matte magnetic surface offers dual-purpose projection cum writing.

**MAGNETIC GREEN BOARD**

- Premium triple acrylic resin coated steel surface with thickness of 0.40 mm. Is chip resistant, making the board ideal for frequent use.The clean smooth, contemporary surface gives advantages for excellent quality writing & will speak volumes about the image of your company.Day-to-Day cleaning with a standard magnetic duster/erasers whilst a good clean surface, good quality marker pens & proper maintenance of the board will ensure remain in tip top condition with no grease or ghost images left behind.

**NON-MAGNETIC GREEN BOARD**

- The durable, melamine surface is chip-resistant & is ideal for general use & does not attracts magnets. Durable with its tough, anodized finish the aluminium frame can withstand everyday wear and tear and stay looking good forever.

CERAMIC BOARD		MAGNETIC BOARD			NON-MAGNETIC BOARD		
SIZE (MM) APPROX.	SIZE (MM) APPROX.	SIZE (MM) APPROX.	SIZE (MM) APPROX.	SIZE (MM) APPROX.	SIZE (MM) APPROX.	SIZE (MM) APPROX.	SIZE (MM) APPROX.
300X450	600X1800	300X450	600X1800	1200X1500	300X450	600X1800	1200X1800
300X600	900X1200	300X600	900X900	1200X1800	300X600	900X900	1200X2400
450X600	1200x1200	450X600	900X1200	1200X2400	450X600	900X1200	1200X3000
450X900	1200X1500	450X900	900X1500	1200X3000	450X900	900X1500	1200X3600
600X600	1200X1800	600X600	900X1800	1200X3600	600X600	900X1800	----
600X900	1200X2400	600X900	900X2400	----	600X900	900X2400	----
600X1200	1200X3000	600X1200	900X3000	----	600X1200	1200x1200	----
600X1500	1200X3600	600X1500	1200x1200	----	600X1500	1200X1500	----

## NON-MAGNETIC GLASS WRITING BOARD



- Apart from the refreshing visual impact that they provide, the quality of the Glass Writing experience is Superb, Simple, Effective & Extraordinary.
- Dry wipe surface in a choice of colours, is a stylish back painted Writing Board that will suit any office, training room or boardroom.
- Clear, toughened safety glass with strong & sturdy satin anodised Stud fixings.
- This exciting and versatile glass alternative to the traditional white marker board can be used in countless settings, such as the office, boardroom, hospitals, doctors surgery, schools and colleges, even in the home now-a-days!
- The Glass Wipe Board will fit perfectly in any work environment or interior setting.
- Manufactured from 6.0mm & 8.0 mm safety glass that also features highly polished rounded edges and corners.
- **Note:** Glass Writing boards can be mounted in portrait or in landscape view. Professional installation may be required where board size dictates. Lead time for this product is around 5-7 working days.

SIZE (MM) APPROX.		
450X600	600X1800	1200X1200
600X900	900X1200	1200X1500
600X1200	900X1500	1200X1800
600X1500	900X1800	1200X2400

## MAGNETIC GLASS WRITING BOARD



- Apart from the refreshing visual impact that they provide, the quality of the Glass Writing experience is Superb, Simple, Effective & Extraordinary.
- Dry wipe surface in a choice of colours, is a stylish back painted Writing Board that will suit any office, training room or boardroom.
- Clear, toughened safety glass with strong & sturdy satin anodised Stud fixings.
- This exciting and versatile glass alternative to the traditional white marker board can be used in countless settings, such as the office, boardroom, hospitals, doctors surgery, schools and colleges, even in the home now-a-days!
- The Glass Wipe Board will fit perfectly in any work environment or interior setting.
- Manufactured from 6.0mm & 8.0 mm safety glass that also features highly polished rounded edges and corners.
- **Note:** Glass Writing boards can be mounted in portrait or in landscape view. Professional installation may be required where board size dictates. Lead time for this product is around 5-7 working days.

SIZE (MM) APPROX.		
450X600	600X1800	1200X1200
600X900	900X1200	1200X1500
600X1200	900X1500	1200X1800
600X1500	900X1800	1200X2400

**FELT PIN UP NOTICE BOARD**



- Well known as Soft Board/Pin-up Board/Bulletin Board used in Schools/Offices/Public Places for display of articles and notices with the help of Push Pins, Drawing Pins etc...
- Non Woven Felt Cloth used for the surface of the Felt Notice Board.
- Felt available in six different colours i.e. Beige/Blue/Green/Grey/Maroon & Red.
- Following The instructions provided, any persons can manage this task easily and safely install the board on the wall using spares supplied inside each board.

SIZE (MM) APPROX.	SIZE (MM) APPROX.	SIZE (MM) APPROX.
300X300	600X1200	900X2400
300X450	600X1500	1200x1200
300X600	600X1800	1200X1500
450X600	900X900	1200X1800
450X900	900X1200	1200X2400
600X600	900X1500	----
600X900	900X1800	----

## FABRIC PIN UP NOTICE BOARD



- Well known as Soft Board/Pin-up Board/Bulletin Board used in Schools/Offices/Public Places for display of articles and notices with the help of Push Pins, Drawing Pins etc...
- Polyester Fabric cloth used for the surface of the Fabric Board
- Fabric available in different colours. Grey/Navy Blue/Light Blue/Red/Green/Maroon/Orange/Yellow
- Following The instructions provided, any persons can manage this task easily and safely install the board on the wall using spares supplied inside each board.

SIZE (MM) APPROX.	SIZE (MM) APPROX.	SIZE (MM) APPROX.
300X300	600X1200	900X2400
300X450	600X1500	1200x1200
300X600	600X1800	1200X1500
450X600	900X900	1200X1800
450X900	900X1200	1200X2400
600X600	900X1500	----
600X900	900X1800	----

## CORK PIN UP NOTICE BOARD



- Surface material Cork Sheet.
- Thickness of the Cork Sheet being 1 mm pasted on a good quality soft board.
- Used in Schools/Offices/Public Places for display of articles and notices with the help of Push Pins, Drawing Pins etc...
- Following The instructions provided, any persons can manage this task easily and safely install the board on the wall using spares supplied inside each board.

SIZE (MM) APPROX.	SIZE (MM) APPROX.	SIZE (MM) APPROX.
300X450	600X1200	1200x1200
300X600	600X1800	1200X1500
450X600	900X900	1200X1800
450X900	900X1200	1200X2400
600X600	900X1500	----
600X900	900X1800	----



## FELT PIN UP NOTICE BOARD

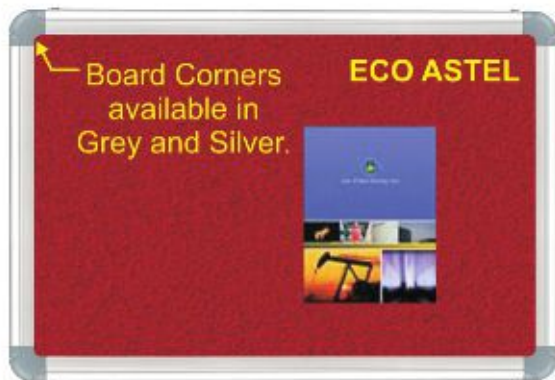

## FABRIC PIN UP NOTICE BOARD

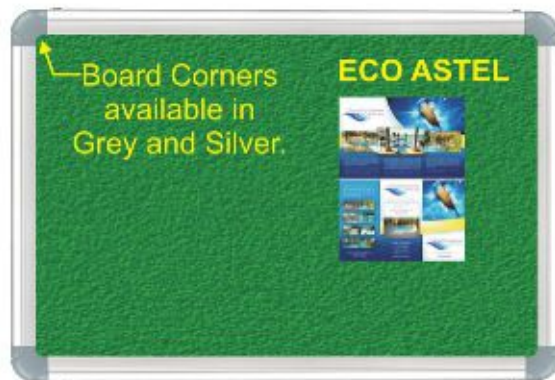

## CORK PIN UP NOTICE BOARD



## FELT PIN UP NOTICE BOARD

- Well known as Soft Board/Pin-up Board/Bulletin Board used in Schools/Offices/Public Places for display of articles and notices with the help of Push Pins, Drawing Pins etc...
- Non Wooven Felt Cloth used for the surface of the Felt Notice Board.
- Felt available in six different colours i.e. Beige/Blue/Green/Grey/Maroon & Red.

## FABRIC PIN UP NOTICE BOARD

- Well known as Soft Board/Pin-up Board/Bulletin Board used in Schools/Offices/Public Places for display of articles and notices with the help of Push Pins, Drawing Pins etc...
- Polyster Fabric cloth used for the surface of the Fabric Board
- Fabric available in different colours. Grey/Navy Blue/Light Blue/Red/Green/Maroon/Orange/Yellow

## CORK PIN UP NOTICE BOARD

- Surface material Cork Sheet.
- Thickness of the Cork Sheet being 1 mm pasted on a good quality soft board.
- Used in Schools/Offices/Public Places for display of articles and notices with the help of Push Pins, Drawing Pins etc...

### FELT PIN UP / FABRIC PIN UP NOTICE BOARD

SIZE (MM) APPROX.	SIZE (MM) APPROX.	SIZE (MM) APPROX.
450X600	900X900	1200X1500
600X600	900X1200	1200X1800
600X900	900X1500	1200X2400
600X1200	900X1800	----
600X1800	1200x1200	----

### CORK PIN UP NOTICE BOARD

SIZE (MM) APPROX.	SIZE (MM) APPROX.
600X900	900X900
600X1200	900X1200
600X1800	----

## FELT/FABRIC PIN UP NOTICE BOARD



6  
COLOURS



8  
COLOURS



- Well known as Soft Board/Pin-up Board/Bulletin Board used in Schools/Offices/Public Places for display of articles and notices with the help of Push Pins, Drawing Pins etc...
- Non Woven Felt Cloth used for the surface of the Felt Notice Board.
- Felt available in six different colours i.e. Beige/Blue/Green/Grey/Maroon & Red.
- Polyester Fabric cloth used for the surface of the Fabric Board
- Fabric available in different colours. Grey/Navy Blue/Light Blue/Red/Green/Maroon/Orange/Yellow
- Following The instructions provided, any persons can manage this task easily and safely install the board on the wall using spares supplied inside each board.

SIZE (MM) APPROX.	SIZE (MM) APPROX.	SIZE (MM) APPROX.
300X300	600X1800	1200X2400
300X450	900X900	----
300X600	900X1200	----
450X600	900X1500	----
450X900	900X1800	----
600X600	1200x1200	----
600X900	1200X1500	----
600X1200	1200X1800	----

## FELT PIN UP NOTICE BOARD



## FABRIC PIN UP NOTICE BOARD



## CORK PIN UP NOTICE BOARD



## FELT PIN UP NOTICE BOARD

- Well known as Soft Board/Pin-up Board/Bulletin Board used in Schools/Offices/Public Places for display of articles and notices with the help of Push Pins, Drawing Pins etc...
- Non Woven Felt Cloth used for the surface of the Felt Notice Board.
- Felt available in six different colours i.e. Beige/Blue/Green/Grey/Maroon & Red.

## FABRIC PIN UP NOTICE BOARD

- Well known as Soft Board/Pin-up Board/Bulletin Board used in Schools/Offices/Public Places for display of articles and notices with the help of Push Pins, Drawing Pins etc...
- Polyster Fabric cloth used for the surface of the Fabric Board
- Fabric available in different colours. Grey/Navy Blue/Light Blue/Red/Green/Maroon/Orange/Yellow

## CORK PIN UP NOTICE BOARD

- Surface material Cork Sheet.
- Thickness of the Cork Sheet being 1 mm pasted on a good quality soft board.
- Used in Schools/Offices/Public Places for display of articles and notices with the help of Push Pins, Drawing Pins etc...

### FELT PIN UP / FABRIC PIN UP NOTICE BOARD

SIZE (MM) APPROX.	SIZE (MM) APPROX.	SIZE (MM) APPROX.
450X600	900X900	1200X1500
600X600	900X1200	1200X1800
600X900	900X1500	1200X2400
600X1200	900X1800	----
600X1800	1200x1200	----

### CORK PIN UP NOTICE BOARD

SIZE (MM) APPROX.	SIZE (MM) APPROX.
600X900	900X900
600X1200	900X1200
600X1800	----

## FELT PIN UP NOTICE BOARD

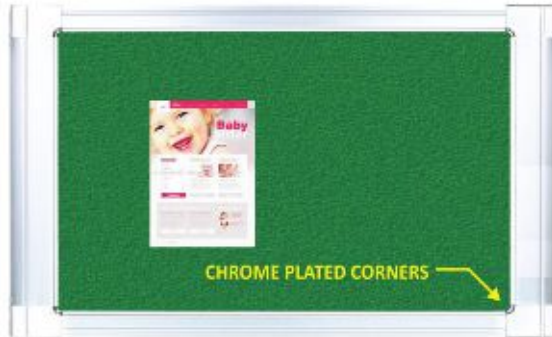

## FABRIC PIN UP NOTICE BOARD

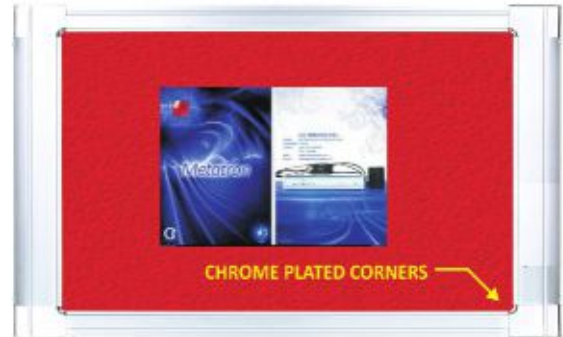

## CORK PIN UP NOTICE BOARD



## FELT PIN UP NOTICE BOARD

- Well known as Soft Board/Pin-up Board/Bulletin Board used in Schools/Offices/Public Places for display of articles and notices with the help of Push Pins, Drawing Pins etc...
- Non Wooven Felt Cloth used for the surface of the Felt Notice Board.
- Felt available in six different colours i.e. Beige/Blue/Green/Grey/Maroon & Red.

## FABRIC PIN UP NOTICE BOARD

- Well known as Soft Board/Pin-up Board/Bulletin Board used in Schools/Offices/Public Places for display of articles and notices with the help of Push Pins, Drawing Pins etc...
- Polyester Fabric cloth used for the surface of the Fabric Board
- Fabric available in different colours. Grey/Navy Blue/Light Blue/Red/Green/Maroon/Orange/Yellow

## CORK PIN UP NOTICE BOARD

- Surface material Cork Sheet.
- Thickness of the Cork Sheet being 1 mm pasted on a good quality soft board.
- Used in Schools/Offices/Public Places for display of articles and notices with the help of Push Pins, Drawing Pins etc...

### FELT PIN UP / FABRIC PIN UP NOTICE BOARD

SIZE (MM) APPROX.	SIZE (MM) APPROX.	SIZE (MM) APPROX.
450X600	900X900	1200X1500
600X600	900X1200	1200X1800
600X900	900X1500	1200X2400
600X1200	900X1800	----
600X1800	1200x1200	----

### CORK PIN UP NOTICE BOARD

SIZE (MM) APPROX.	SIZE (MM) APPROX.
600X900	900X900
600X1200	900X1200
600X1800	----

## FELT PIN UP NOTICE BOARD



6 COLOURS 

## FABRIC PIN UP NOTICE BOARD



8 COLOURS 

## CORK PIN UP NOTICE BOARD

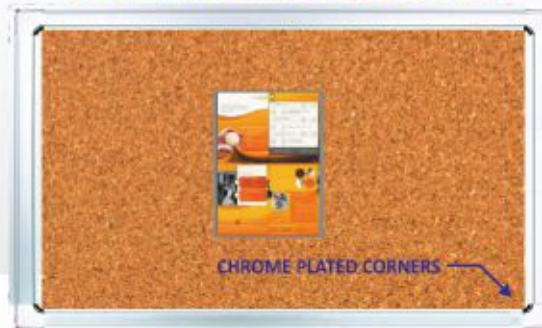

## FELT PIN UP NOTICE BOARD

- Well known as Soft Board/Pin-up Board/Bulletin Board used in Schools/Offices/Public Places for display of articles and notices with the help of Push Pins, Drawing Pins etc...
- Non Woven Felt Cloth used for the surface of the Felt Notice Board.
- Felt available in six different colours i.e. Beige/Blue/Green/Grey/Maroon & Red.

## FABRIC PIN UP NOTICE BOARD

- Well known as Soft Board/Pin-up Board/Bulletin Board used in Schools/Offices/Public Places for display of articles and notices with the help of Push Pins, Drawing Pins etc...
- Polyester Fabric cloth used for the surface of the Fabric Board
- Fabric available in different colours. Grey/Navy Blue/Light Blue/Red/Green/Maroon/Orange/Yellow

## CORK PIN UP NOTICE BOARD

- Surface material Cork Sheet.
- Thickness of the Cork Sheet being 1 mm pasted on a good quality soft board.
- Used in Schools/Offices/Public Places for display of articles and notices with the help of Push Pins, Drawing Pins etc...

SIZE (MM) APPROX.	SIZE (MM) APPROX.	SIZE (MM) APPROX.
300X300	600X1200	900X2400
300X450	600X1500	1200x1200
300X600	600X1800	1200X1500
450X600	900X900	1200X1800
450X900	900X1200	1200X2400
600X600	900X1500	----
600X900	900X1800	----

## DOUBLE SIDED BOARD

FRONT SIDE WHITE MARKER/GREEN CHALK  
BACK SIDE GREEN CHALK/WHITE MARKER



FRONT SIDE WHITE MARKER/FELT OR FABRIC PIN UP NOTICE BOARD  
BACK SIDE FELT OR FABRIC/WHITE MARKER.



- Two-sided boards with surfaces in White Marker + Green Chalk + Display, which offer the possibility to Write & Pin Up on any sides, exploiting the space available at best. A great choice for schools, offices, businesses, hospitals or any area where lectures or lessons are given.
- This both Sided board after mounting on a Revolving Stand, can rotate by 360° and be locked in the desired position with a help of the knob affixed on Stand. Stable and compact structure of the stand can be moved on Castor wheels.
- Possibility to match useful combinations, Front/Back for Writing (Non Magnetic, Magnetic & Ceramic) Like, White Marker + White Marker or White Marker + Green Chalk or Green Chalk + Green Chalk.
- Can match possible combinations, Front/Back for Writing & Display (Non Magnetic, Magnetic & Ceramic) Like White Marker + Felt Pin Up Notice Board or White Marker + Fabric Pin Up Notice Board. One Side can be Used for Writing & other side for Display.
- Can match possible combinations, Front/Back for Display Like Felt + Felt or Fabric + Fabric. Both the Sides can be used for displaying Notices in Passages, Lobby, Receptions, Conference areas or Exhibitions Halls and many more places.
- These both Sided Boards are suitable for mounting on Revolving Stands, 3 Leg Stands, & 4 Leg Stands, 'A' Type Display Stands only & 'Y' Type Stands with a set of Hingis.
- These Boards are not provided with any Wall mounting arrangements.
- Also available in Economy Astel Series

### SIZE (MM) APPROX.

450X600	900X1200	1200X1500	1200X2400
600X900	900X1500	1200X1800	----

**DOUBLE SIDED BOARD**

**FRONT SIDE WHITE MARKER/GREEN CHALK  
BACK SIDE GREEN CHALK/WHITE MARKER**



**FRONT SIDE WHITE MARKER/FELT OR FABRIC PIN UP NOTICE BOARD  
BACK SIDE FELT OR FABRIC/WHITE MARKER.**

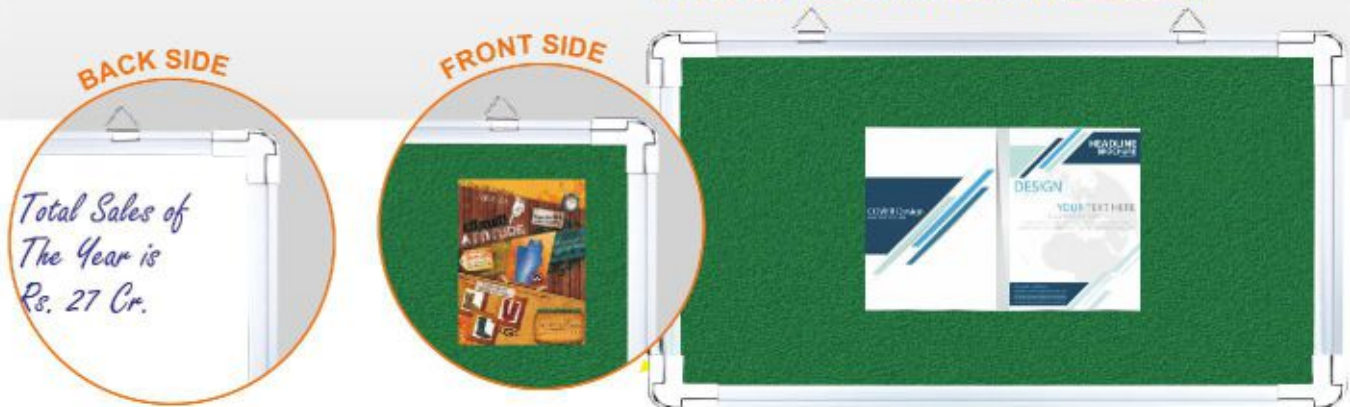

**8**  
COLOURS  
FABRIC



**6**  
COLOURS  
FELT



- Two-sided boards with surfaces in White Marker + Green Chalk + Display, which offer the possibility to Write & Pin Up on any sides, exploiting the space available at best. A great choice for schools, offices, any area where lectures or lessons are given.
- Possibility to match useful combinations, Front/Back for Writing (Non Magnetic, Magnetic & Ceramic) Like, White Marker + White Marker or White Marker + Green Chalk or Green Chalk + Green Chalk.
- Can match possible combinations, Front/Back for Writing & Display (Non Magnetic, Magnetic & Ceramic) Like White Marker + Felt Pin Up Notice Board or White Marker + Fabric Pin Up Notice Board. One Side can be Used for Writing & other side for Display.
- Can match possible combinations, Front/Back for Display Like Felt + Felt or Fabric + Fabric. Both the Sides can be used for displaying Notices in Passages, Lobby, Receptions, Conference areas or Exhibitions Halls and many more places.
- These Boards can be used on both the sides with a unique set of hanging hooks provided on the frame, wherein you can easily remove or Hang/mount the board for utilizing any writing surface either ways.
- Following the instructions provided, any persons can manage this task easily and safely install the board on the wall using spares supplied inside each board.
- These both Sided Boards can be easily mounted on 3 Leg Stands, 4 Leg Stands, 'A' Type Display Stands & on 'Y' Type Stands with a set of Hinges.
- Also available in Economy Hanging Series

**SIZE (MM) APPROX.**

300X450	600X900	900X1500	1200X1500	1200X2400
450X600	900X1200	900X1800	1200X1800	---

**GROOVE BOARD**



**DOOR COVERED GROOVE BOARD**



**SIZES OF GOLDEN LETTERS & FIGURES**

LETTERS SET OF 112			FIGURES SET OF 100		
AEIO	5 Each	20 Pcs.	150	14 Each	42 Pcs.
CNRST	4 Each	20 Pcs.	2	10 Each	10 Pcs.
BDFGHK	3 Each	18 Pcs.	346	8 Each	24 Pcs.
LMPUWY	3 Each	18 Pcs.	789	8 Each	24 Pcs.
JQV	2 Each	06 Pcs.			
XZ	1 Each	02 Pcs.		Total	100Pcs.
.	-	10 Pcs.			
:	-	04 Pcs.			
-	-	05 Pcs.			
()	-	02 Pcs.			
& % /	-	04 Pcs.			
	Total	112 Pcs.			

SIZE OF LETTERS	SIZE OF FIGURES
18mm	18mm
24mm	24mm
36mm	36mm

**GROOVE BOARD WITH GOLDEN STAND**



**GROOVE BOARD**

Very popularly known as Menu Board/Welcome/Display Board. Used in Offices/Hotels/Auditorium & Public Places for display information. Groove Board Velvet Colours available Red, Maroon & Black. Golden Letters & Figures are available in 18mm/24mm/36mm in English. Following the instructions provided, any person can manage this task easily and safely install the board on the wall using spares supplied inside each board.

**DOOR COVERED GROOVE BOARD**

Front Door Covered with golden alluminium framed acrylic sheet with lock and keys attachment.

**GOLDEN STAND**

Golden Stand for Groove Boards strong iron casted golden base. Height of the Golden Pipe 6ft.

SIZE (MM) APPROX. GROOVE BOARDS			
300X450	600X600	600X1200/P	900X1200/P
450X600/P	600X900/P	1200X600/L	1200X900/L
600X450/L	900X600/L	900X900	1200X1200

SIZE (MM) APPROX. DOOR COVERED GROOVE NOTICE BOARDS	
450X600	900X900
600X900	900X1200
600X1200	----



## PERFORATED DISPLAY BOARD



- Very Popularly known as Menu Board/Welcome/Display Board used in Offices/Hotels/Auditorium and Public Places for Display Information.
- Plastic Letters & Figures are available in English in different Sizes : 12mm/18mm/24mm/36mm.
- Following the instructions provided, any person can manage this task easily and safely install the board on the wall using spares supplied inside each board.

SIZE (MM) APPROX.	SIZE (MM) APPROX.	SIZE (MM) APPROX.
300X300	600X1200	900X3000
300X450	600X1800	1200x1200
300X600	900X900	1200X1500
450X600	900X1200	1200X1800
450X900	900X1500	1200X2400
600X600	900X1800	----
600X900	900X2400	----

**LETTERS & FIGURES FOR PERFORATED DISPLAY BOARD**



- Available in four sizes ie. 12mm, 18mm, 25mm, 36mm in white colour.
- Letter Sets of 112 Alphabets & Figure Sets of 100 Numericals.
- All Sets of Letters & Figures are packed in Plastic Box.
- Letters & Figures Sets are available in English only.

LETTERS SET OF 112		
<b>AEIO</b>	5 Each	20 Pcs.
<b>CNRST</b>	4 Each	20 Pcs.
<b>BDFGHK</b>	3 Each	18 Pcs.
<b>LMPUWY</b>	3 Each	18 Pcs.
<b>JQV</b>	2 Each	06 Pcs.
<b>XZ</b>	1 Each	02 Pcs.
.	-	10 Pcs.
'	-	04 Pcs.
-	-	05 Pcs.
( )	-	02 Pcs.
& % /	-	04 Pcs.
	<b>Total</b>	<b>112 Pcs.</b>

FIGURES SET OF 100		
<b>150</b>	14 Each	42 Pcs.
<b>2</b>	10 Each	10 Pcs.
<b>346</b>	8 Each	24 Pcs.
<b>789</b>	8 Each	24 Pcs.
	<b>Total</b>	<b>100Pcs.</b>

SIZE OF LETTERS	SIZE OF FIGURES
12mm	12mm
18mm	18mm
24mm	24mm
36mm	36mm

## DOOR COVERED NOTICE BOARD

### REGULAR SERIES

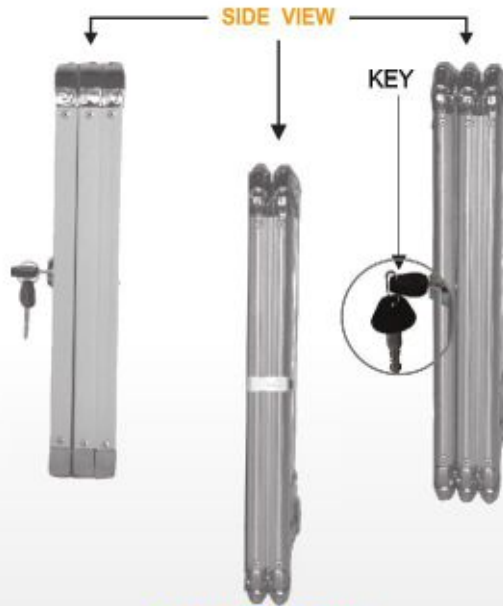

### ASTEL SERIES



SINGLE ASTEL

## HANGING SERIES

Front Door Covered with alluminium framed acrylic sheet which can be locked with a pair of keys provided with each board. The Board is backed with a soft board. Accepts Push Pins, Drawing Pins etc....

Felt available in different colours. Green/Light Blue/Beige/Red/Grey/Maroon



Fabric available in different colours. Green/Light Blue/Navy Blue/Orange/Red/Grey/Maroon/Yellow



SIZE (MM) APPROX. REGULAR & ASTEL SERIES		
450X600	900X1200	1200X1800
600X900	900X1500	1200X2400
600X1200	900X1800	----
900X900	1200X1500	----

SIZE (MM) APPROX. HANGING SERIES		
450X600	900X1200	1200X1800
600X900	900X1500	----
600X1200	900X1800	----
900X900	1200X1500	----

**SLIDING GLASS DOOR COVER BOARDS**

**SLIDING GLASS DOOR COVER  
FELT/FABRIC PIN UP NOTICE BOARD**



SIZE (MM) APPROX.		
450X600	900X1200	1200X1500
600X900	900X1500	1200X1800
600X1200	900X1800	1200X2400

**SLIDING GLASS DOOR COVER  
MAGNETIC WRITING BOARD**



SIZE (MM) APPROX.	
600X900	1200X1800
900X1200	1200X2400
1200X1500	-----

**SLIDING GLASS DOOR COVER  
KEY HOLDING BOARD**



- Available Capacity of holding Keys :  
50 Keys & 100 Keys
- Size : 50 Keys : 630mmX620mm  
100 Keys : 630mmX1020mm

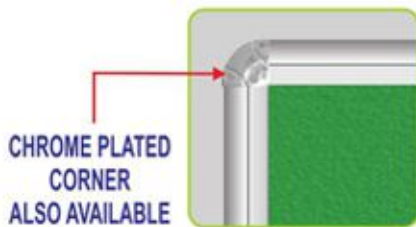

**SLIDING GLASS DOOR COVER  
FELT/FABRIC PIN UP NOTICE BOARD**

- Surface Material Available : Felt/Fabric/Cork
- Easy to pin up Notices, Flyers, Messages etc.

**SLIDING GLASS DOOR COVER  
MAGNETIC WRITING BOARD**

- Surface Material Resin Coated Magnetic Writing Board
- Magnetic Push Pins, Magnetic Buttons can be used to put notices, flyers, Messages etc.

**SLIDING GLASS DOOR COVER  
KEY HOLDING BOARD**

- Numbers printed on Steel Plate & Key Chain for Identification.

**COMMON SPECIFICATION**

- Sliding Glass moves smoothly on bearings.
- Lock provided on the sliding glass to keep Keys safe.
- Two keys provided with lock for safety.
- Sturdy Aluminium Frame 30mmX50mm
- MS Brackets provided at the back of the board, for installation on the wall.

**KEY BOARDS**

**KEY BOARD WITH 10 KEYS**



**REGULAR FRAME**

**KEY BOARD WITH 30 KEYS**



**ASTEL FRAME**

**KEY BOARD WITH 40 KEYS**



**ASTEL FRAME**

**KEY BOARD WITH 20 KEYS**



**REGULAR FRAME**

- Convenient way for storing keys with lock.
- Door cover with locking method.
- Sizes for storage : 20, 30, 40, 50 & 100 Keys.
- Paper slip in the Key Chain itself for writing information.

DESCRIPTION	SIZE (MM) APPROX.
Board for 20 Keys	300X450
Board for 30 Keys	450X410
Board for 40 Keys	450X510
Board for 50 Keys	450X610
Board for 100 Keys	785X900

DIM KIT



- Both side board.
- Can easy assembled on occasion.
- Strong hinges provided for proper locking of the board on the stand.
- Display in minutes. Available in non woven felt & polyester fabric.
- Felt available in six different colours i.e. Beige/Blue/Green/Grey/Maroon & Red.
- Fabric available in different colours. Grey/Navy Blue/Light Blue/Red/Green/Maroon/Orange/Yellow
- Sizes available in 600X900mm & 900X1200mm.

PLANNER BOARD



MONTHLY PLANNER

Available in Landscape size only.  
Size : 600X900mm.



WEEKLY PLANNER

Available in Portrait size only.  
Size :300X450mm. - P



YEARLY PLANNER

Available in Landscape size only.  
Size : 600X900mm.

PLANNER BOARD - YEARLY PLANNER

- Triple acrylic resin coated imported steel surface.
- Yearly Planner with adjustable magnetic Sunday blocks in red colour.
- Can be easily hanged on the wall with wall hanging attachments or counseled metal clamps.

PLANNER BOARD - MONTHLY & WEEKLY PLANNER

- Triple acrylic resin coated imported steel surface. Accepts Magnet.
- Can be easily hanged on the wall with wall hanging attachments or counseled metal clamps.

## BOARD STANDS

### FLIP CHART BOARD WITH HOLDER & THREE LEG STAND



THREE LEG STAND

FLIP CHART HOLDER



- FLIP CHART WRITING BOARD**
- Especially Designed for meeting rooms/ Conference Rooms & for Presentations Halls.
  - Board available in Non-Magnetic/Magnetic & Ceramic Surfaces.
  - Standard Board Size is 700 x 1000 mm.

- FLIP CHART HOLDER**
- Very economical paper holding system.
  - Made of M.S. Steel powder coated.
  - Size of the holder is 600 mm.

- FLIP CHART PAPER**
- Used for mounting on flip chart holders.
  - Thickness of the paper 75gms.
  - Size of the paper is 585 X 900 mm.



### WOODEN STAND FOR WOODEN FRAME BOARDS

AVAILABLE SIZES  
5 FEET & 6 FEET

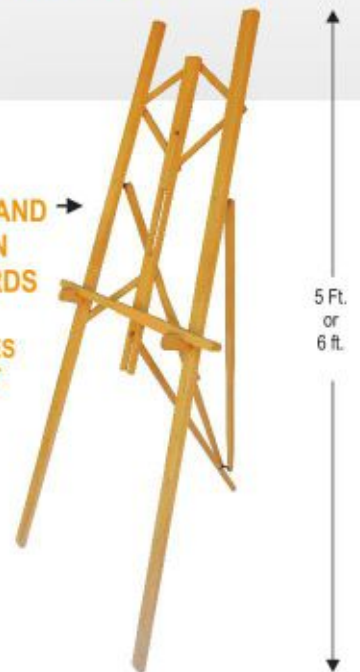

- THREE LEG STAND**
- Three leg display stand strong and sturdy.
  - Non skid rubber pads provided for the board to rest.
  - Holes provided for the board adjustments.
  - 5 ft. Height available for board size upto 600 X 900 mm.
  - 6 ft. Height available for board size upto 900 X 1200 mm.
  - Available in 1" X 1" & 3/4" X 3/4" in M.S. Pipe.
  - Order board separately.
  - Colour available : Powder Coated Grey & Black

- WOODEN STAND**
- Used to Mount Wooden Frame Boards.
  - Available Sizes 5 ft. & 6 ft.
  - Order board separately.

**BOARD STANDS**

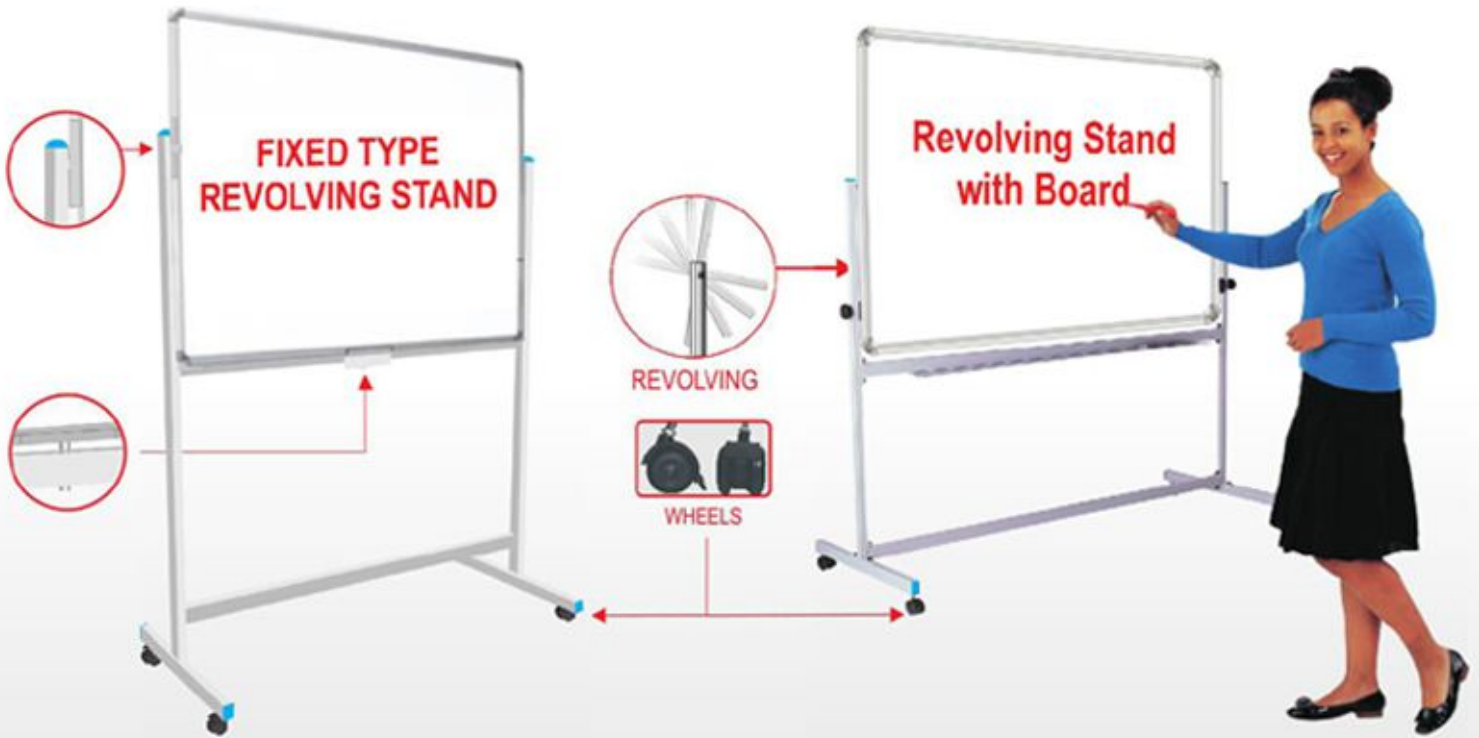

**FIXED TYPE REVOLVING STAND**

- ✔ For fixed single & double side boards.
- ✔ Heavy duty castors provided to move the stand.
- ✔ Can be easily assembled.
- ✔ Suitable for board size 600X900mm., 900X1200mm., 1200X1500mm., 1200X1800mm., 1200X2400mm.
- ✔ Order Board separately.

**REVOLVING STAND**

- ✔ For Single and double side Boards.
- ✔ Board can be locked with a sturdy locking attachments.
- ✔ Heavy duty castors provided to move the stand.
- ✔ Can be easily assembled.
- ✔ Suitable for board size 600X900mm., 900X1200mm., 1200X1500mm., 1200X1800mm., 1200X2400mm.
- ✔ Order Board separately.

**FOUR LEGGED DISPLAY STAND**

- ✔ Four legged display stand for bigger sized boards strong and sturdy.
- ✔ Can be easily assembled.
- ✔ Suitable for board size above 900X1200mm. & upto 1200X2400mm.
- ✔ Order board separately.





## FIXED TYPE MOVABLE STAND

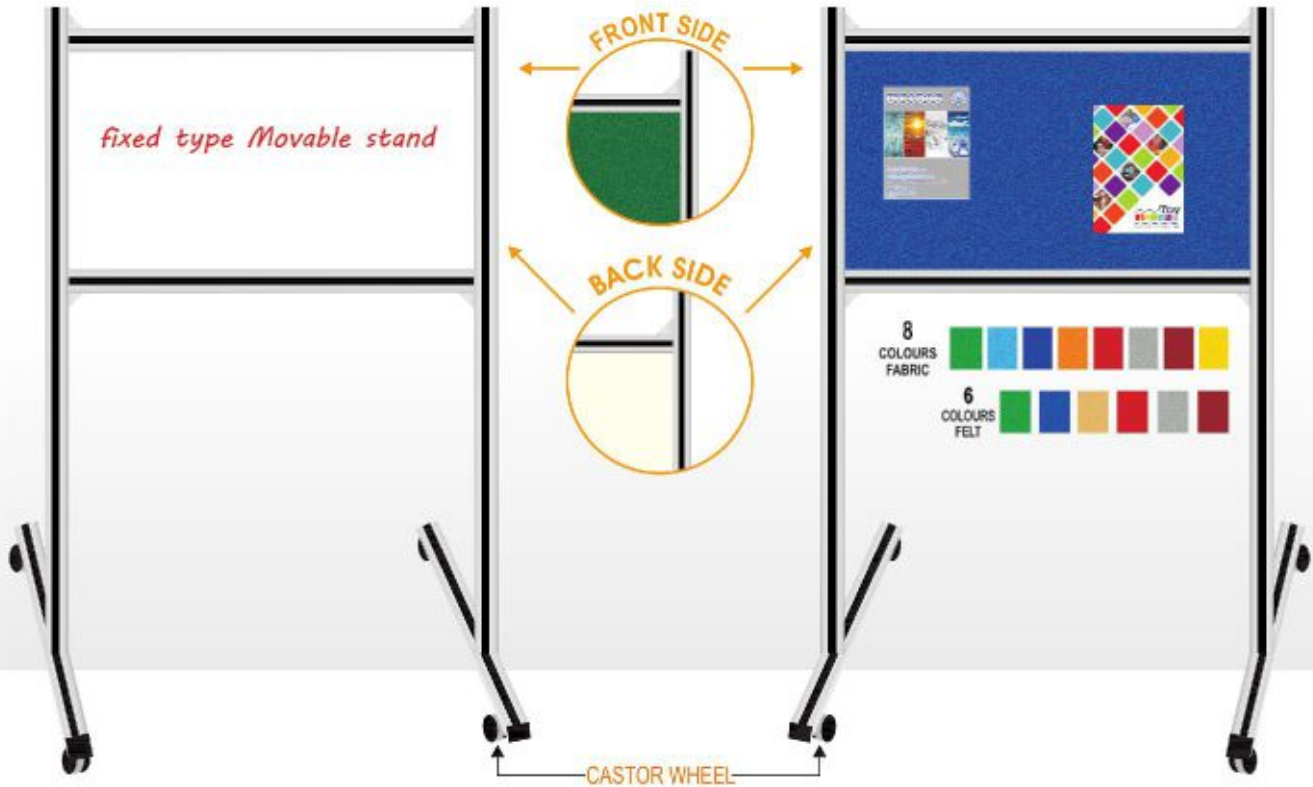

- Made from Heavy Duty Aluminium Profile.
- For fixed single & double side boards.
- Heavy Duty Castors provided to move the Stand.
- Can be easily assembled.

### Can install it both side :

- Non Magnetic + Non Magnetic, Non Magnetic + Felt / Fabric
- Magnetic + Magnetic, Magnetic + Felt / Fabric
- Ceramic + Ceramic, Ceramic + Felt / Fabric
- Felt / Fabric + Felt / Fabric

**All Fitting accessories provided with the stand.**

SIZE (MM) APPROX.	SIZE (MM) APPROX.	SIZE (MM) APPROX.
600X900	900X1500	1200X1800
600X1200	900X1800	1200X2400
900X900	1200X1200	----
900X1200	1200X1500	----

## BOARD STANDS



LOBBY STAND  
WITHOUT WHEELS

LOBBY STAND  
WITH WHEELS

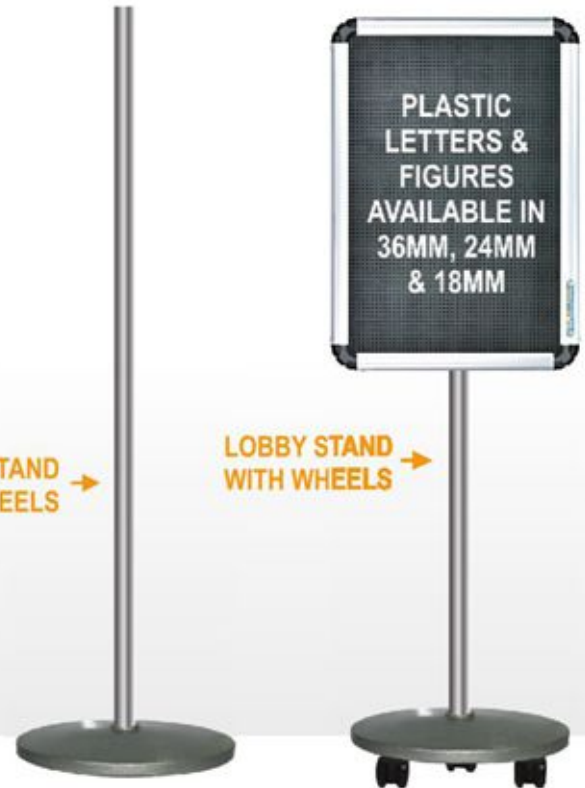

### LOBBY STAND

- Consists of heavy duty threaded base strong aluminium anodised pipe of 6Ft. Height.
- Two Nylon Holders with one stand required to install board size upto 600X900mm.
- Four Nylon holders with two stands can be fixed on the boards size above 600X900mm.
- Four caster Wheels provided for the Lobby Stand to make it movable.
- Order board & stand separately.

**BOARD ACCESSORIES**

**PUSH PINS**



**PUSH PINS**

- Top needle being Chrome Plated does not rust.
- Round Thick Diameter gives a better grip on the paper while pinning.
- 1 Set contains of 12 Push Pins available in 6 different colours.

**MAGNETIC PUSH PINS**



**MAGNETIC PUSH PINS**

- Round Shaped Magnetic Push Pins.
- Strong Magnets can hold thick paper at a time.
- Transparent & Coloured Pins Available.
- 1 Small Plastic Box contains = 4 Pcs.

**MAGNETIC LETTERS & FIGURES**

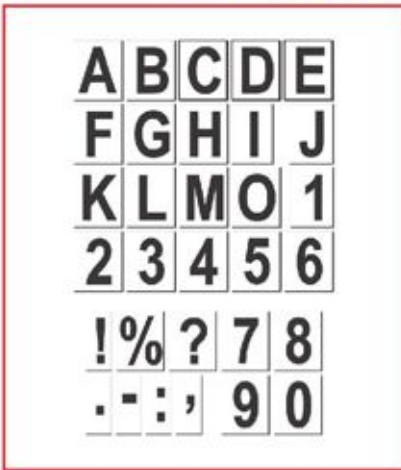

**20 mm**

Letters Set of 112 Pcs. + 112 Pcs. = 224 Pcs.  
Figures Set of 100 Pcs. + 100 Pcs. = 200 Pcs.

**30 mm**

Letters Set of 112 Pcs.  
Figures Set of 100 Pcs.

LETTERS SET OF 112 PCS.		
A E I O		20 Pcs.
C N R S T		20 Pcs.
B D F G H K		18 Pcs.
L M P U W Y		18 Pcs.
J Q V		6 Pcs.
Z X		2 Pcs.
▪		10 Pcs.
%		1 Pc.
:		1 Pc.
,		5 Pcs.
-		5 Pcs.
?		2 Pcs.
+		1 Pc.
=		1 Pc.
!		2 Pcs.
<b>Total</b>		<b>112 Pcs.</b>

FIGURES SET OF 112 PCS.		
1 5 0	14 Each	42 Pcs.
2	10 Each	10 Pcs.
3 4 6	8 Each	24 Pcs.
7 8 9	8 Each	24 Pcs.
<b>Total</b>		<b>112 Pcs.</b>

**MAGNETIC BUTTONS**



Size : 40mm



Size : 30mm

**MAGNETIC BUTTONS**

- 40mm Round Shaped Magnetic Buttons.
- Strong Magnets can hold thick paper at a time.
- 1 Set = 4 Pcs.

**MAGNETIC BUTTONS**

- 30mm Round Shaped Magnetic Buttons.
- Strong Magnets can hold thick paper at a time.
- 1 Set = 6 Pcs.

**MAGNETIC LETTERS & FIGURES**

- Used on Magnetic Resin Coated Board to display menus at the reception

**BOARD ACCESSORIES**



**PEN TRAY**



**CHROME PLATED**



**GREY**

**PEN TRAY**

- Ideal to keep Marker Pens & Chalks
- Colours available Grey & Chrome Plated

**MAGNETIC DUSTER**



**NON MAGNETIC  
CHALK BOARD DUSTER**



**NON MAGNETIC  
MARKER BOARD DUSTER**



**NON MAGNETIC CHALK BOARD DUSTER**

- Suitable for Green & Black Chalk Boards.
- Wipes Smoothly and Cleanly with the help of good quality Felt Cloth.
- Manufactured with best quality of Plastic & Felt.
- The size of the Duster is handy and can be kept easily in the Pen Tray attached to the board.

**NON MAGNETIC MARKER BOARD DUSTER**

- Suitable for Non-Magnetic White Marker Boards.
- Wipes Smoothly and Cleanly with the help of good quality Felt Cloth.
- Manufactured with best quality of Plastic & Felt.
- The size of the Duster is handy and can be kept easily in the Pen Tray attached to the board.

**MAGNETIC BOARD DUSTER**

- Suitable for Magnetic White Marker Boards & Ceramic White Boards.
  - The Duster having magnetic property to hold them to remain fixed on the board.
  - Wipes Smoothly and Cleanly with the help of good quality Felt Cloth.
  - Manufactured with best quality of Plastic & Felt.
- The size of the Duster is handy and can be kept easily in the Pen Tray attached to the board.

**ACRYLIC PRODUCTS**



← ACRYLIC WRITING DESK

SUGGESTION BOX →



↑ BUSINESS CARD HOLDER

MENU HOLDER →



**ACRYLIC WRITING DESK**

- Convenient to use on table.
- Can be adjust in suitable angle.
- Can hold paper from the top.

**SUGGESTION BOX**

- Holds comment cards, business cards etc.
- Made of clear acrylic.
- Insertion slot on top with sliding opening from back side.

**MENU HOLDER**

- Displays Menu on table.

**BUSINESS CARD HOLDER**

- Convenient to keep business cards in one place.
- It can hold minimum 100 cards easily.

SUGGESTION BOX SIZE (MM) APPROX.	ACRYLIC WRITING DESK SIZE (MM) APPROX.	MENU HOLDER SIZE (MM) APPROX.
200 X 200 X 300	580 X 400	125 X 180
150 X 150 X 250	-----	-----

## ACRYLIC PRODUCTS

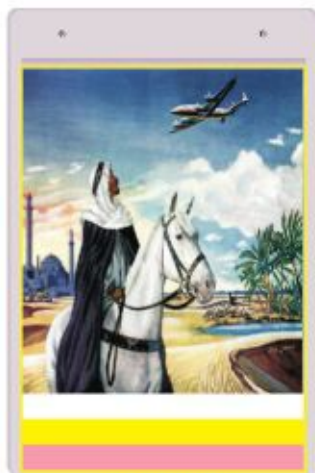

**PORTRAIT**

### ← WALL INFORMATION HOLDER

Available in Portrait. & Landscape



**LANDSCAPE**

### WALL INFORMATION HOLDER

- It can fix easily on wall, door etc. With the help of two predrilled holes.
- Made from clear acrylic.
- Information can be easily insert from top of the holder.

Art No.	Sizes
A4 H-WIIP	210 X 297
A4 H-WIIL	297 X 210
A5 H-WIIP	148 X 210
A5 H-WIIL	210 X 148
A6 H-WIIP	105 X 148
A6 H-WIIL	148 X 105

**Size**  
235W X 275H x 90 D. mm



**Size**  
110W X 197H X 80 D. mm



### ↑ LITERATURE HOLDER

- Holds literatures for distribution.
- Predrilled holes for fitting on walls.
- Made from clear acrylic sheet.

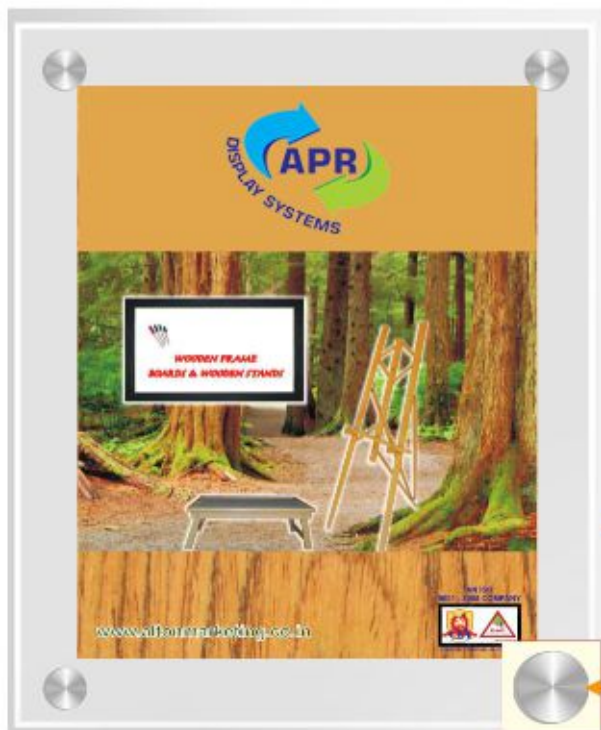

### ← WALL LITERATURE HOLDER

Available Size : A6, A5, A4, A3,  
600X900mm & 900X1200mm  
Can be customised also.

### ← WALL MOUNTING STUD

### WALL LITERATURE HOLDER

- Brass Nickle plated screws & nuts for fixing on the wall.
- Opens from front for paper insertion.

## SLIDING GLASS BOARD ASSEMBLY PROCEDURE

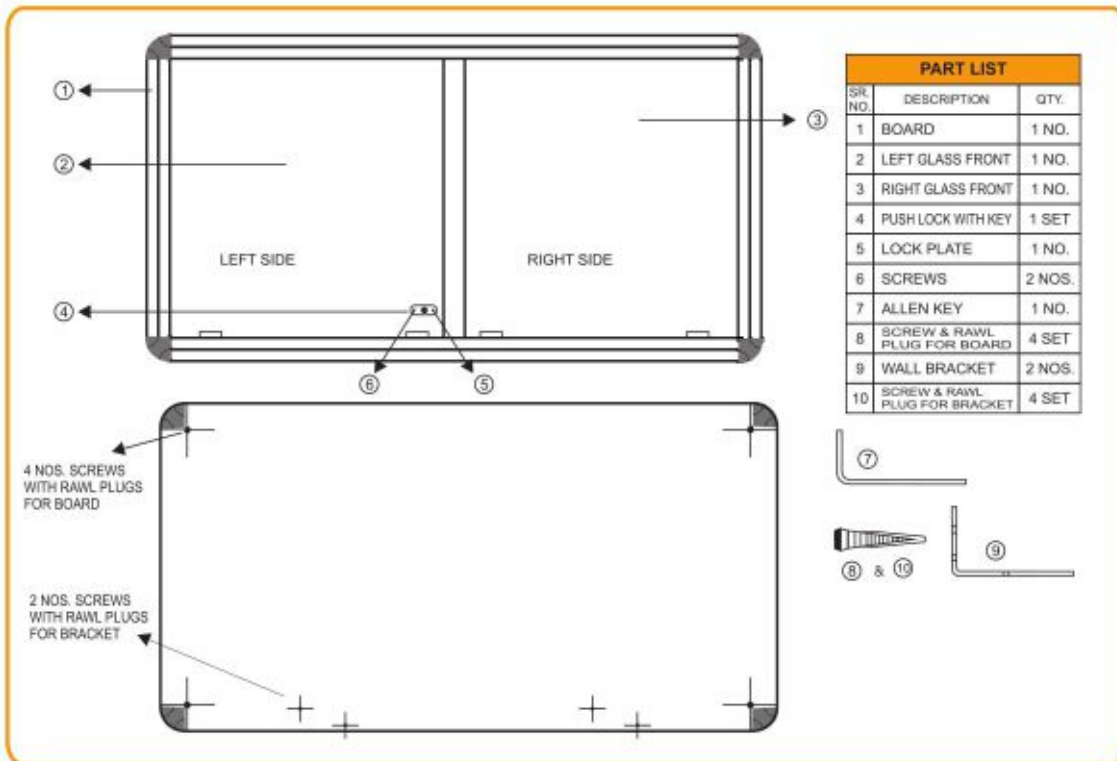

### Sliding Glass Board consist of the following Parts/Components.

1. Board in assembled condition. (Without glass and lock)
2. Left Glass (front) with hole for lock and screws with two glass runners.
3. Right Glass ( back) with two glass runners.
4. Push Lock with key.
5. Lock Plate
6. Two numbers screws to fix lock plate with locks.
7. Allen keys.
8. Fixing Screws and Rawl Plugs.
9. Two numbers "L" Type wall mounting brackets.

### Assembly Procedure.

Open carton and take out all the items as listed above.

### Steps of Assembly

- STEP 1:** First fix the board without glass on the wall with four screws and rawl plugs. Take left glass and assemble lock and lock plate by pushing lock from back side of the glass. Place lock plate on projected portion of the lock from front. Put two screws from front and fasten it with Allen Keys
- STEP 2:** HOLD RIGHT glass in both the hands and place it on the back channel top side and then on bottom side. Glass size is kept in such a way that it can be easily placed in the back channel.
- STEP 3:** HOLD LEFT glass in both the hands and first place it in front channel top side and then on bottom side.
- STEP 4:** MARK the bottom line of the board and fix the two ("L" Bracket) support so that board can easily be mounted on the "L" Brackets & then fix the screen provided on the bottom frame.
- STEP 5:** Place board on wall after screws and brackets are fixed.

**LINE DIAGRAM FOR MOUNTING OF THE BOARD ON THE WALL**



**LINE DIAGRAM FOR MOUNTING OF THE BOARD ON THE WALL**

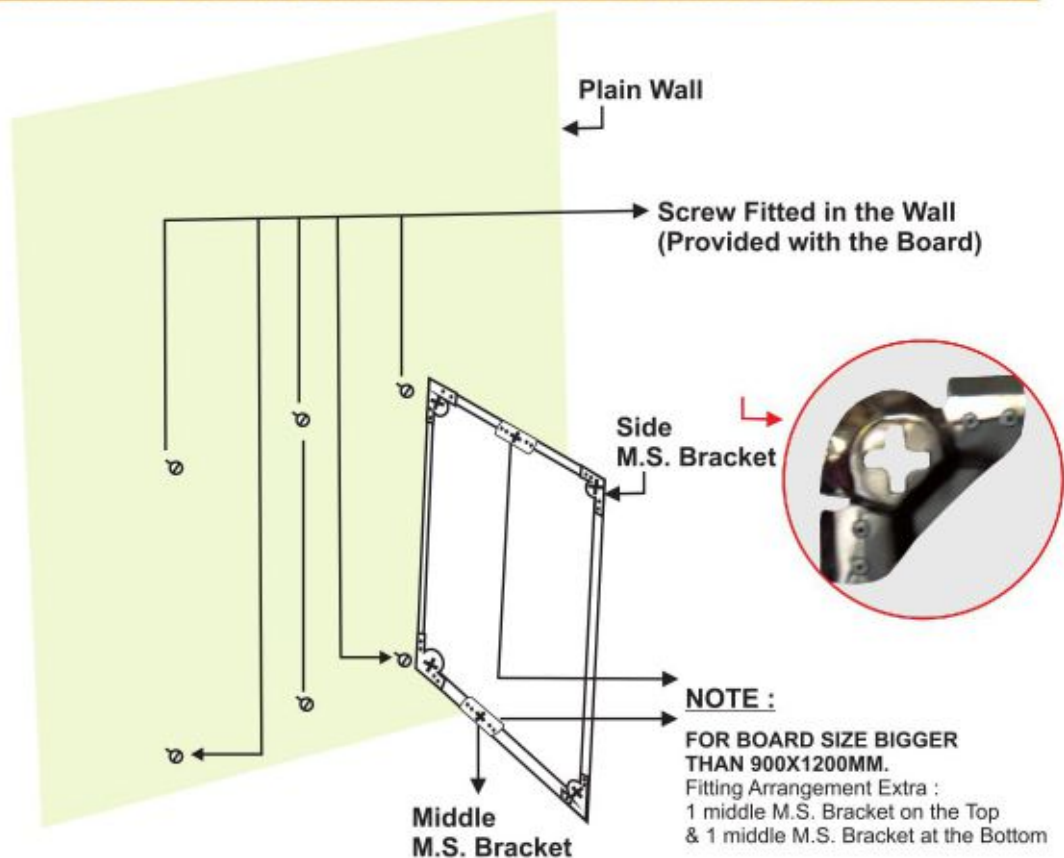

**IMPORTANT NOTICE :**

Improper or Insufficient Fitting of the M.S.Brackets on the wall provided on the Board will result in bending or humping of the Board for which the company is not responsible.



## LINE DIAGRAM FOR FITTING OF PLASTIC PEN TRAY ON THE ASTEL FRAME BOARD

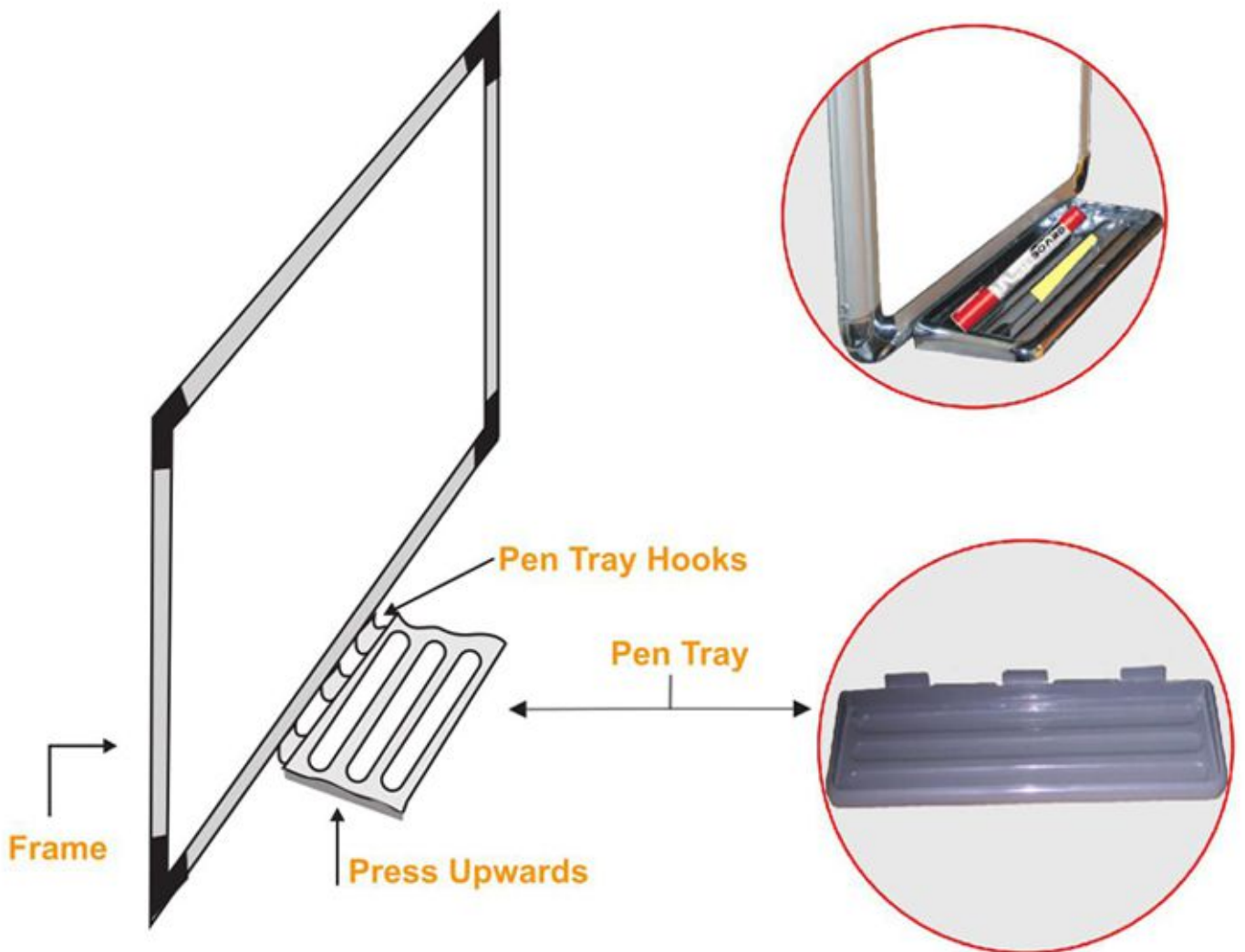

**GUIDE FOR CARE & MAINTENANCE OF WHITE MARKER / CHALK BOARDS****DRY ERASE MARKERS / CHALKS**

All dry marker can be used on White Writing Boards but for best performance use solvent based markers.

**NOTE:** Some type of chalk are incompatible with chalk boards and may scratch the surface due to rough particles.

**WHITE BOARDS / CHALK BOARDS**

- A. Before using your Magnetic White / Chalk Board for the first time remove the protective films from the surface.
- B. Spray the Board with any Dry Board cleaner and wipe with a soft cloth or duster.
- C. Rinse with clear water. This step is simple but very important.
- D. Wipe with Dry Cloth.

**EVERY DAY CARE**

If your Board is used daily full cleaning should be done regularly. More thorough cleaning may be required if texts are left on the board formore than 2 days.

**Periodic cleaning is recommended for problem free longevity of this Board.**

**A clean Board is a well prepared Board and a well prepared Board gives a well presented presentation.**

**DO NOT USE PERMANENT MARKERS**

**PERMANENT MARKERS INK CAN BE REMOVED BY ISOPROPYL ALCOHOL**